



# PARTS CATALOGUE

**YZ85X** (5PAK) USA,CANADA

**YZ85** (5PAK) EUROPE,SOUTH AFRICA

**YZ85** (5PAM) JAPAN

**YZ85LW** (5SHK) EUROPE,SOUTH AFRICA

**YZ85LW** (5SHM) JAPAN

YZ85X  
YZ85/YZ85LW  
PARTS CATALOGUE  
©2007 by Yamaha Motor Co., Ltd.  
1st edition, May 2007  
All rights reserved.  
Any reprinting or unauthorized use  
without the written permission of  
Yamaha Motor Co., Ltd.  
is expressly prohibited.

**A3**

# FOREWORD

This Parts Catalogue is related to the parts for the model(s) on the cover page. When you are ordering replacement parts, please refer to this Parts Catalogue and quote both part numbers and part names correctly.

1. Modifications or additions which have been made after the issue of the Parts Catalogue will be announced in the Parts News.

It is advisable that you make the necessary corrections to the Parts Catalogue according to the Parts News.

2. Abbreviations

The following abbreviations are used in this Parts Catalogue.

“UR” Use specified parts number.

“UN” Use as many as needed.

“AP” Alternate Parts

“LM” Locally Made (Parts need to be ordered locally)

“F#” Frame No. (Applicable machine No.)

“O/S” Over Size

3. The number of components for assembly

- Parts, which are to be supplied in an assembly, are listed with a dot (.) in front of the part name as shown below.
- The numeral appearing to the right of each component part indicates the quantity of parts for each assembly unit.

PART NO.	DESCRIPTION	Q'TY	REMARKS
2F5-83310-60	FRONT FLASHER LIGHT ASSY	2	
115-83311-60	.BULB (6V-18W)	1	

4. Applicable colours of graphics are represented in the “REMARKS” as shown below.

PART NO.	DESCRIPTION	Q'TY	REMARKS
2N4-24110-00-X5	FUEL TANK COMP.	2	MXR
3J1-24240-10	.GRAPHIC, FUEL TANK	1	FOR MXR

5. Note that the illustrations for reference in finding parts numbers are not to be used for assembling. When assembling, please use the applicable service manual.

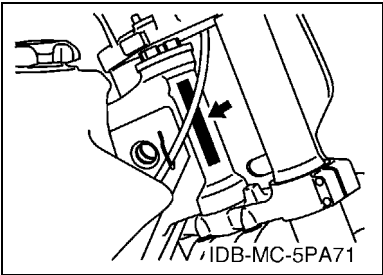
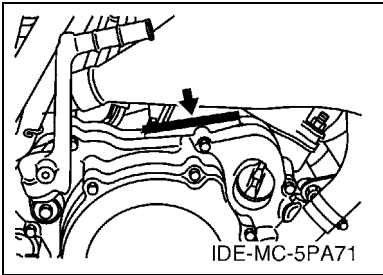
6. The asterisk (\*) before a reference number indicates modified items after the first edition.

# FOREWORD

7. Applicable Serial No.

Engine Serial No.

Frame Serial No.



8. Applicable Colour Code (The (\*) mark shows Model colour.)

Abbreviation	Colour Name	Colour Code
DPBSE(*)	DEEP PURPLISH BLUE SOLID E	0583
YB	YAMAHA BLACK	0033



# CONTENTS

## ENGINE

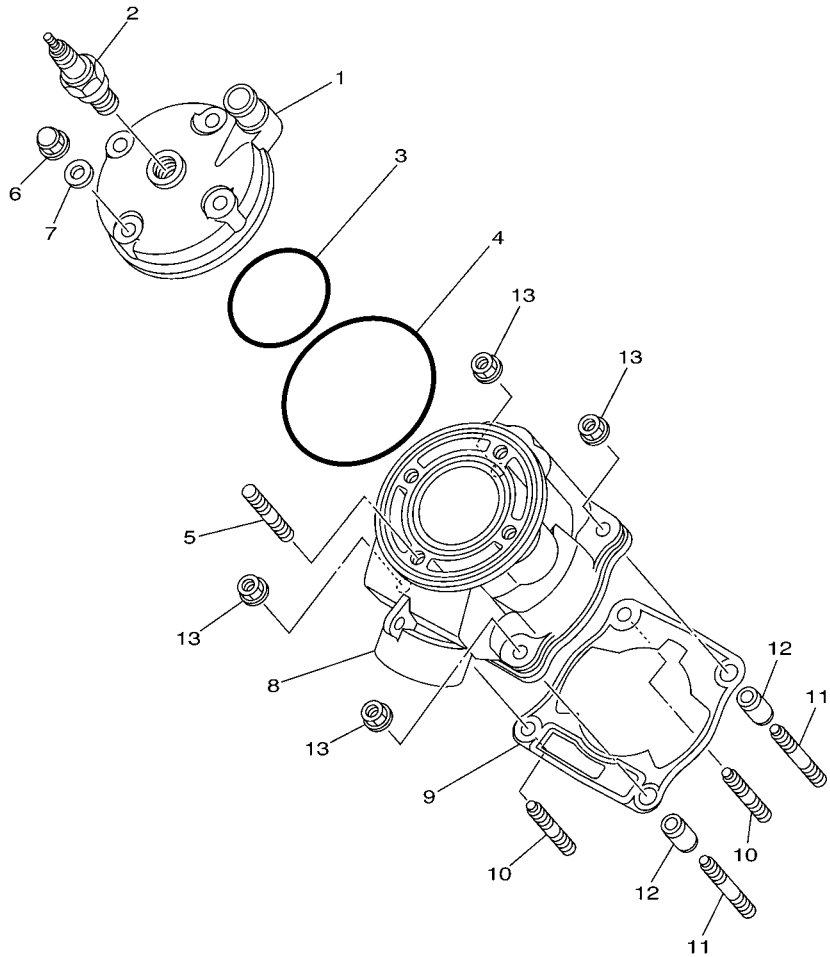
CYLINDER .....	B2
CRANKSHAFT & PISTON .....	B3
WATER PUMP .....	B4
RADIATOR & HOSE .....	B5
INTAKE .....	B6
CARBURETOR .....	B7
EXHAUST .....	B9
CRANKCASE .....	B10
CRANKCASE COVER 1 .....	B11
STARTER .....	B12
CLUTCH .....	B13
TRANSMISSION .....	B14
SHIFT CAM & FORK .....	C2
SHIFT SHAFT .....	C3

## CHASSIS

FRAME .....	C4
FENDER .....	C5
SIDE COVER .....	C6
REAR ARM .....	C7
REAR SUSPENSION .....	C9
STEERING .....	C11
FRONT FORK .....	C12
FUEL TANK .....	C15
SEAT .....	D2
FRONT WHEEL .....	D3
FRONT BRAKE CALIPER .....	D4
REAR WHEEL .....	D5
REAR BRAKE CALIPER .....	D7
STEERING HANDLE & CABLE .....	D8
FRONT MASTER CYLINDER .....	D9
STAND & FOOTREST .....	D10
REAR MASTER CYLINDER .....	D11
GENERATOR .....	D12
HANDLE SWITCH & LEVER .....	D13
ELECTRICAL 1 .....	D14
ALTERNATE FOR CHASSIS .....	D15
OPTIONAL PARTS 1 .....	E2

## INDEX

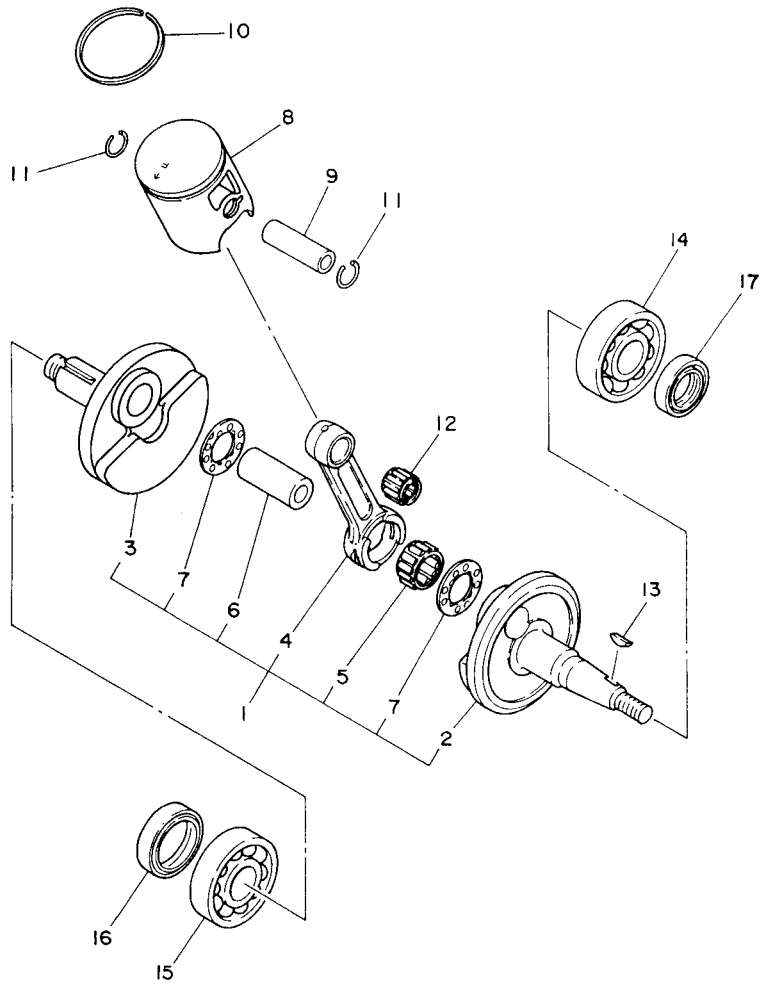
NUMERICAL INDEX .....	M1
-----------------------	----



5PA1100-A010

FIG. 1 CYLINDER

REF. NO.	PART NO.	DESCRIPTION	SPAK	SPAM	SSHK	SSHM	REMARKS
1	5PA-11111-00	HEAD, CYLINDER 1	1	1	1	1	
2	94702-00368	PLUG, SPARK (NGK BR10EG)	1	1			
	94709-00368	PLUG, SPARK (NGK BR10EG)		1	1		
3	93210-56459	O-RING	1	1	1	1	
4	93210-84724	O-RING	1	1	1	1	
5	90116-08027	BOLT, STUD	4	4	4	4	
6	90176-08005	NUT, CROWN	4	4	4	4	
7	90201-080L8	WASHER, PLATE	4	4	4	4	
8	5PA-11311-10	CYLINDER 1	1	1	1	1	
9	4ES-11351-00	GASKET, CYLINDER	1	1	1	1	
10	90116-08031	BOLT, STUD	2	2	2	2	
11	90116-08028	BOLT, STUD	2	2	2	2	
12	99590-10114	PIN, DOWEL	2	2	2	2	
13	90179-08019	NUT	4	4	4	4	



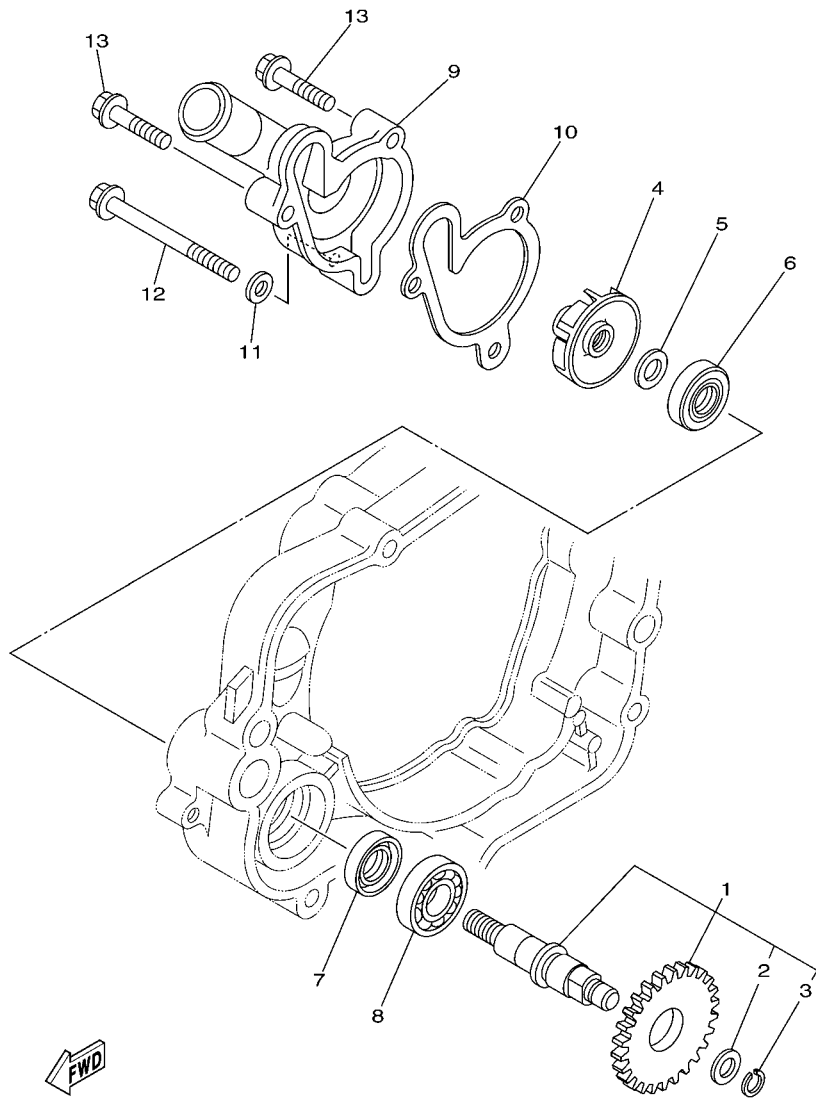
4ES1100-3020

FIG. 2 CRANKSHAFT & PISTON

REF. NO.	PART NO.	DESCRIPTION	5PAK	5PAM	5SHK	5SHM	REMARKS
1	5PA-11400-00	CRANKSHAFT ASSY	1	1	1	1	
2	5PA-11412-00	.CRANK 1	1	1	1	1	
3	5PA-11422-00	.CRANK 2	1	1	1	1	
4	4ES-11651-10	.ROD, CONNECTING	1	1	1	1	
5	93310-420B1	.BEARING	1	1	1	1	
6	2RA-11681-00	.PIN, CRANK 1	1	1	1	1	
7	90209-20159	.WASHER	2	2	2	2	
8	5PA-11631-00-A0	PISTON (STD)	1	1	1	1	UR RED
	5PA-11631-00-B0	PISTON (STD)	1	1	1	1	UR ORANGE
	5PA-11631-00-C0	PISTON (STD)	1	1	1	1	UR GREEN
	5PA-11631-00-D0	PISTON (STD)	1	1	1	1	UR PURPLE
9	4ES-11633-00	PIN, PISTON	1	1	1	1	
10	5PA-11611-00	RING, PISTON	1	1	1	1	
11	93450-16115	CIRCLIP	2	2	2	2	
12	93310-21417	BEARING	1	1	1	1	
13	90280-03017	KEY, WOODRUFF	1	1	1	1	
14	93306-20438	BEARING	1	1	1	1	
15	93306-30421	BEARING	1	1	1	1	
16	93102-28009	OIL SEAL	1	1	1	1	
17	93102-20447	OIL SEAL	1	1	1	1	

**B3**



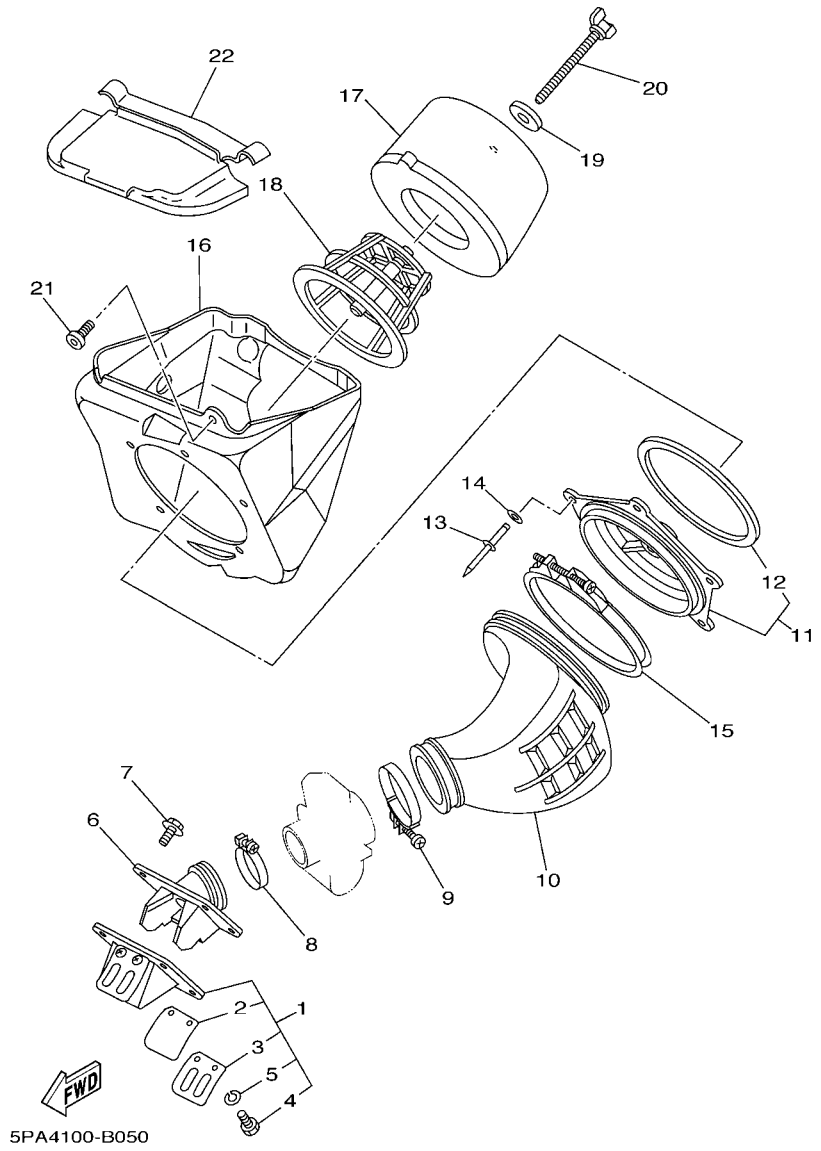


5PA1100-A030

FIG. 3 WATER PUMP

REF. NO.	PART NO.	DESCRIPTION	5PAK	5PAM	5SHK	5SHM	REMARKS
1	5PA-12459-00	GEAR, IMPELLER SHAFT	1	1	1	1	
2	90201-08512	.WASHER, PLATE	1	1	1	1	
3	93440-07182	.CIRCLIP	1	1	1	1	
4	5PA-12451-00	IMPELLER, WATER PUMP	1	1	1	1	
5	90201-08512	WASHER, PLATE	1	1	1	1	
6	93109-11073	OIL SEAL	1	1	1	1	
7	93102-12106	OIL SEAL (SD 12-22-5 HS)	1	1	1	1	
8	93306-00105	BEARING	1	1	1	1	
9	4BA-12422-00	COVER, HOUSING	1	1	1	1	
10	4BA-12428-00	GASKET, HOUSING COVER 2	1	1	1	1	
11	90430-06166	GASKET	1	1	1	1	
12	95822-06060	BOLT, FLANGE	1	1	1	1	
13	95022-06025	BOLT, FLANGE	2	2	2	2	

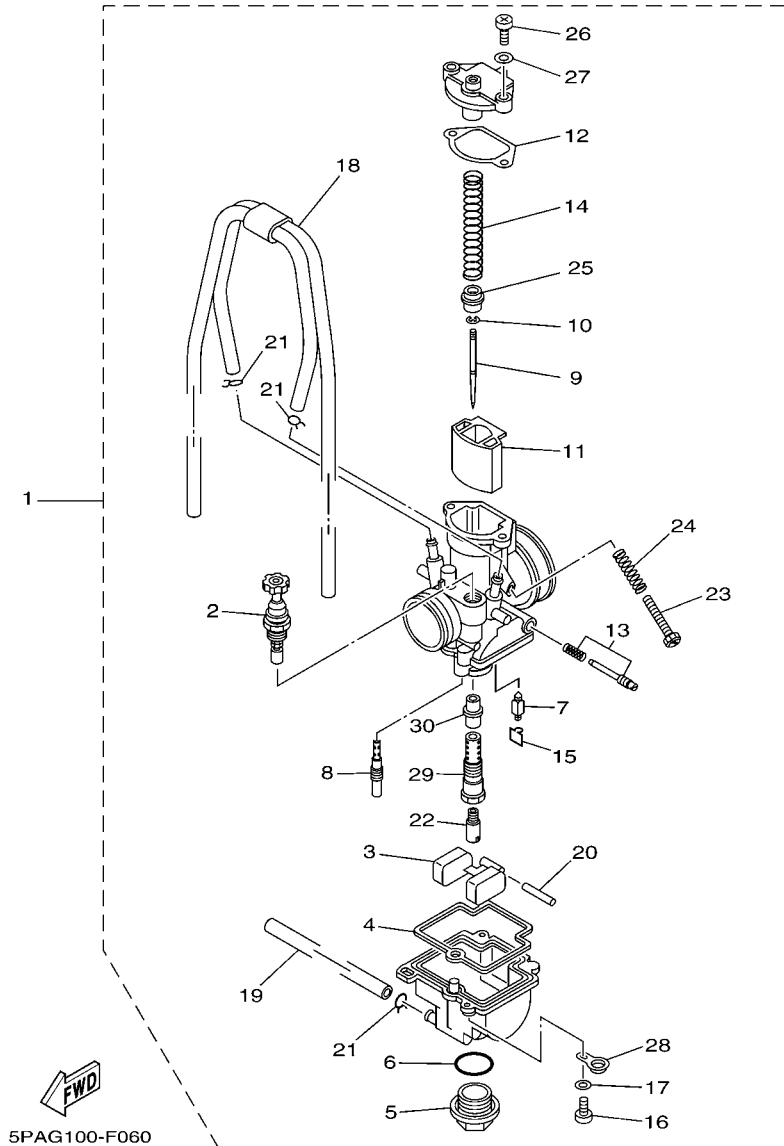




**FIG. 5 INTAKE**

REF. NO.	PART NO.	DESCRIPTION	SPAK	SPAM	SSHK	SSHM	REMARKS
1	4ES-13610-00	REED VALVE ASSY	1	1	1	1	
2	4ES-13613-00	.REED, VALVE	2	2	2	2	
3	4ES-13616-00	.STOPPER, REED VALVE	2	2	2	2	
4	98507-03008	.SCREW, PAN HEAD	4	4	4	4	
5	92907-03100	.WASHER, SPRING	4	4	4	4	
6	5PA-13565-00	JOINT, CARBURETOR	1	1	1	1	
7	95022-06020	BOLT, FLANGE	4	4	4	4	
8	90460-41191	CLAMP, HOSE	1	1	1	1	
9	90460-56105	CLAMP, HOSE	1	1	1	1	
10	5PA-14453-00	JOINT, AIR CLEANER 1	1	1	1	1	
11	5PA-14459-00	HOLDER, GUIDE	1	1	1	1	
12	4ES-14462-00	.SEAL	1	1	1	1	
13	90267-48138	RIVET, BLIND	5	5	5	5	
14	90201-043H7	WASHER, PLATE	5	5	5	5	
15	90450-99064	HOSE CLAMP ASSY	1	1	1	1	
16	5PA-14411-00	CASE, AIR CLEANER 1	1	1	1	1	
17	5PA-14451-00	ELEMENT, AIR CLEANER	1	1	1	1	
18	5PA-14458-00	GUIDE	1	1	1	1	
19	90209-06096	WASHER	1	1	1	1	
20	90122-06002	BOLT, WING	1	1	1	1	
21	90109-065F3	BOLT	1	1	1	1	
22	5PA-14417-00	COVER 1	1	1	1	1	AP

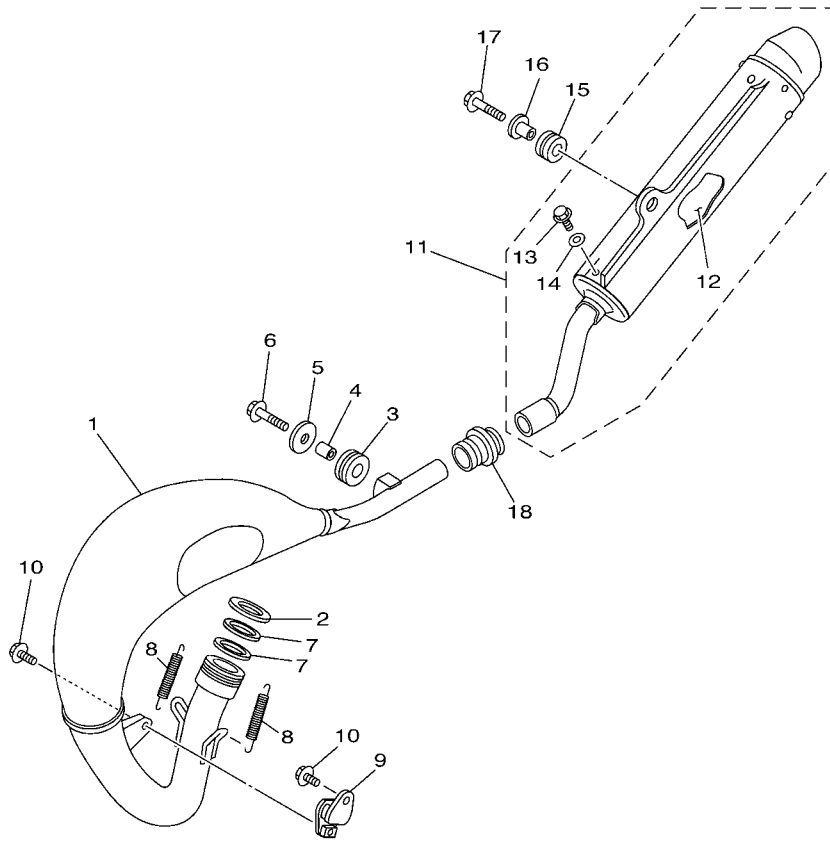
FIG. 6 CARBURETOR



REF. NO.	PART NO.	DESCRIPTION	SPA1	SPAM	SSHK	SSHM	REMARKS
1	5PA-14101-00	CARBURETOR ASSY 1	1	1	1	1	
2	4JT-14171-00	.PLUNGER, STARTER	1	1	1	1	
3	5PA-14985-00	.FLOAT	1	1	1	1	
4	5PA-14984-00	.GASKET, FLOAT CHAMBER	1	1	1	1	
5	4MX-14115-00	.PLUG, SCREW	1	1	1	1	
6	4MX-14561-00	.O-RING	1	1	1	1	
7	5PA-14392-00	.VALVE, NEEDLE	1	1	1	1	
8	4MX-14948-05	.JET, SLOW (#45)	1	1	1	1	STD
	4MX-14948-04	.JET, SLOW (#42)	1	1	1	1	AP
	4MX-14948-06	.JET, SLOW (#48)	1	1	1	1	AP
9	5PA-14916-KF	.NEEDLE (NBKF)	1	1	1	1	STD
	5PA-14916-LE	.NEEDLE (NBLE)	1	1	1	1	AP
	5PA-14916-LF	.NEEDLE (NBLF)	1	1	1	1	AP
	5PA-14916-LG	.NEEDLE (NBLG)	1	1	1	1	AP
	5PA-14916-KE	.NEEDLE (NBKE)	1	1	1	1	AP
	5PA-14916-KG	.NEEDLE (NBKG)	1	1	1	1	AP
10	4MX-14919-00	.CLIP	1	1	1	1	
11	5PA-14340-00	.VALVE ASSY	1	1	1	1	
12	5PA-14126-00	.GASKET	1	1	1	1	
13	5PA-14105-00	.PILOT SCREW SET	1	1	1	1	
14	5PA-14131-00	.SPRING, THROTTLE VALVE	1	1	1	1	
15	5PA-14159-00	.CLIP	1	1	1	1	
16	98504-04014	.SCREW, PAN HEAD	2	2	2	2	
17	92903-04600	.WASHER	2	2	2	2	
18	5PA-1410E-00	.HOSE	1	1	1	1	
19	4XL-14197-10	.PIPE	1	1	1	1	
20	676-14548-00	.PIN, FLOAT ARM	1	1	1	1	



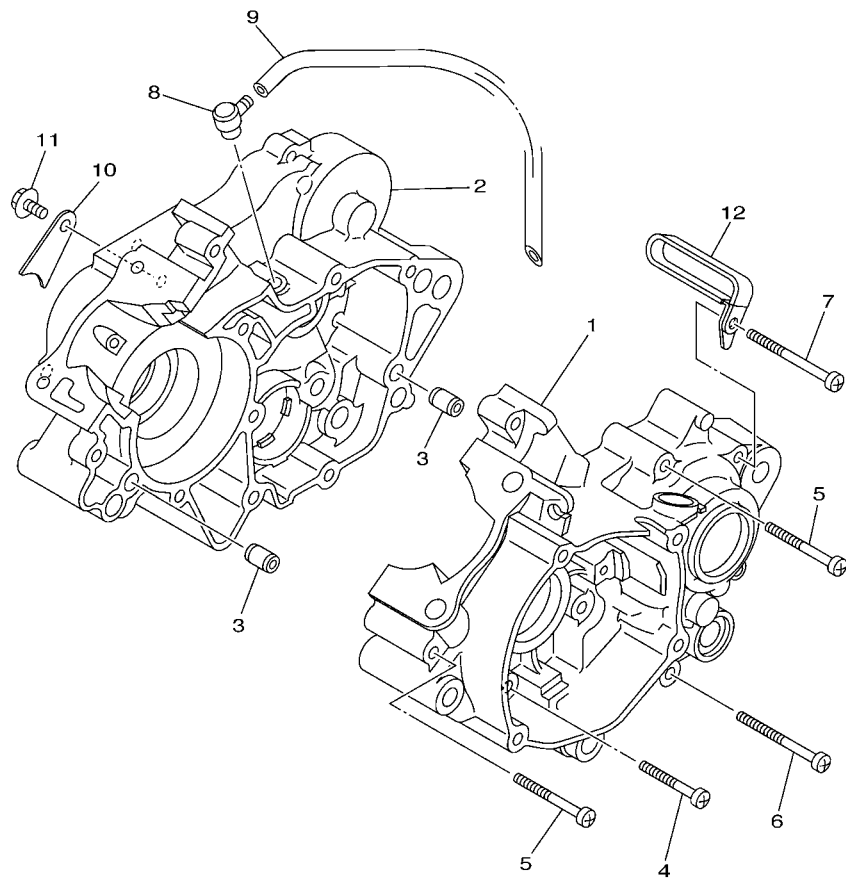
FIG. 7 EXHAUST



REF. NO.	PART NO.	DESCRIPTION	SPAK	SPAM	SSHK	SSHM	REMARKS
1	5PA-14610-00	EXHAUST PIPE ASSY 1	1	1	1	1	
2	90201-33299	WASHER, PLATE	1	1	1	1	
3	90480-18411	GROMMET	1	1	1	1	
4	90387-105L0	COLLAR	1	1	1	1	
5	90201-06086	WASHER, PLATE	1	1	1	1	
6	95022-06025	BOLT, FLANGE	1	1	1	1	
7	5PA-14642-00	SEAL, EXHAUST	2	2	2	2	
8	90507-20052	SPRING, TENSION	2	2	2	2	
9	565-14771-00	STAY, MUFFLER 1	1	1	1	1	
10	90119-06217	BOLT, WITH WASHER	2	2	2	2	
11	4ES-14753-20	SILENCER, EXHAUST	1	1	1	1	UR EXCEPT FOR EUR
	5PA-14753-00	SILENCER, EXHAUST	1	1	1	1	UR FOR EUR
12	4ES-1469A-00	.FIBER	1	1	1	1	UR EXCEPT FOR EUR
	5PA-1469A-00	.FIBER	1	1	1	1	UR FOR EUR
13	92012-06010	.BOLT, BUTTON HEAD	2	2	2	2	
14	90201-06089	.WASHER, PLATE	2	2	2	2	
15	90480-16561	GROMMET	1	1	1	1	
16	90387-063G3	COLLAR	1	1	1	1	
17	95022-06025	BOLT, FLANGE	1	1	1	1	
18	17W-14615-00	JOINT, EXHAUST 1	1	1	1	1	



5PA4100-B070



**FIG. 8 CRANKCASE**

REF. NO.	PART NO.	DESCRIPTION	5PAK	5PAM	5SHK	5SHM	REMARKS
1	5PA-15111-00	CRANKCASE 1	1	1	1	1	
2	5PA-15121-10	CRANKCASE 2	1	1	1	1	
3	99530-10014	PIN, DOWEL	2	2	2	2	
4	98502-06040	SCREW, PAN HEAD	3	3	3	3	
5	98502-06050	SCREW, PAN HEAD	4	4	4	4	
6	98502-06060	SCREW, PAN HEAD	3	3	3	3	
7	98502-06070	SCREW, PAN HEAD	1	1	1	1	
8	353-13115-01	CONNECTOR, SUCTION PIPE	1	1	1	1	
9	90445-08376	HOSE (L330)	1	1	1	1	
10	5PA-15118-00	HOLDER	1	1	1	1	
11	90105-08126	BOLT, FLANGE	1	1	1	1	
12	90461-10136	CLAMP	1	1	1	1	

  
5PA4100-B080

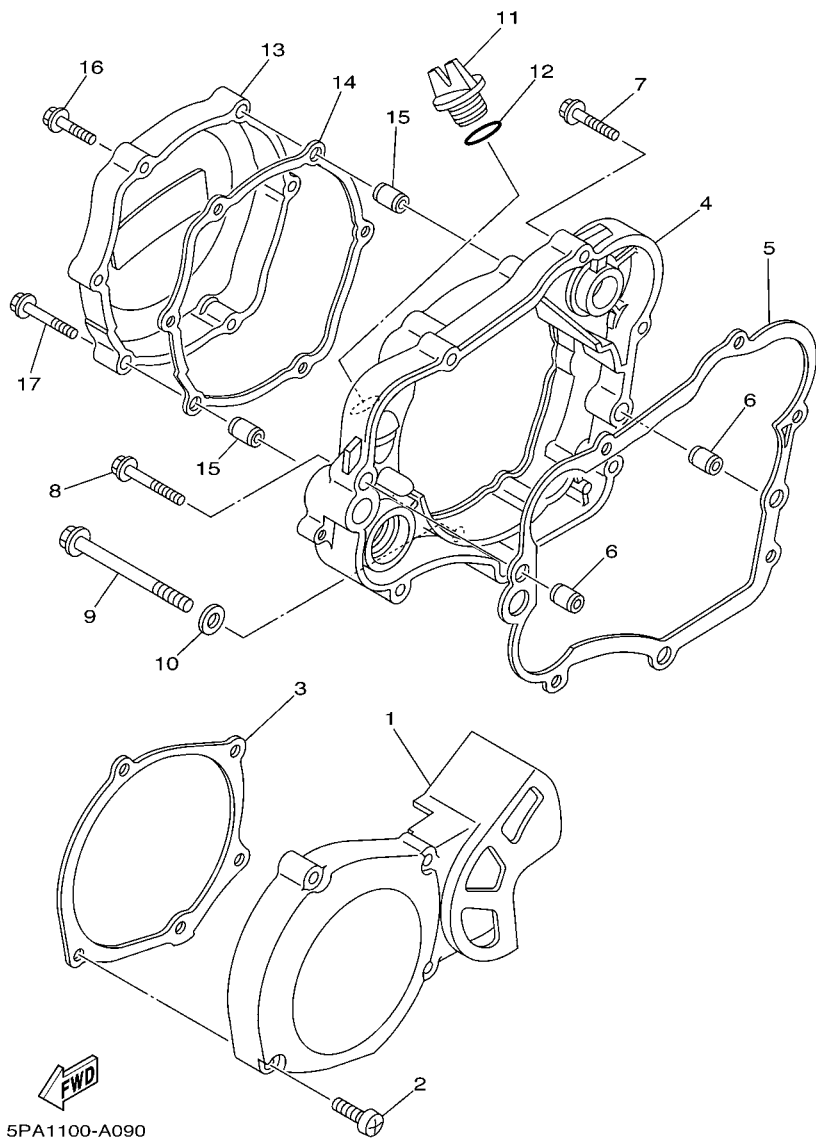
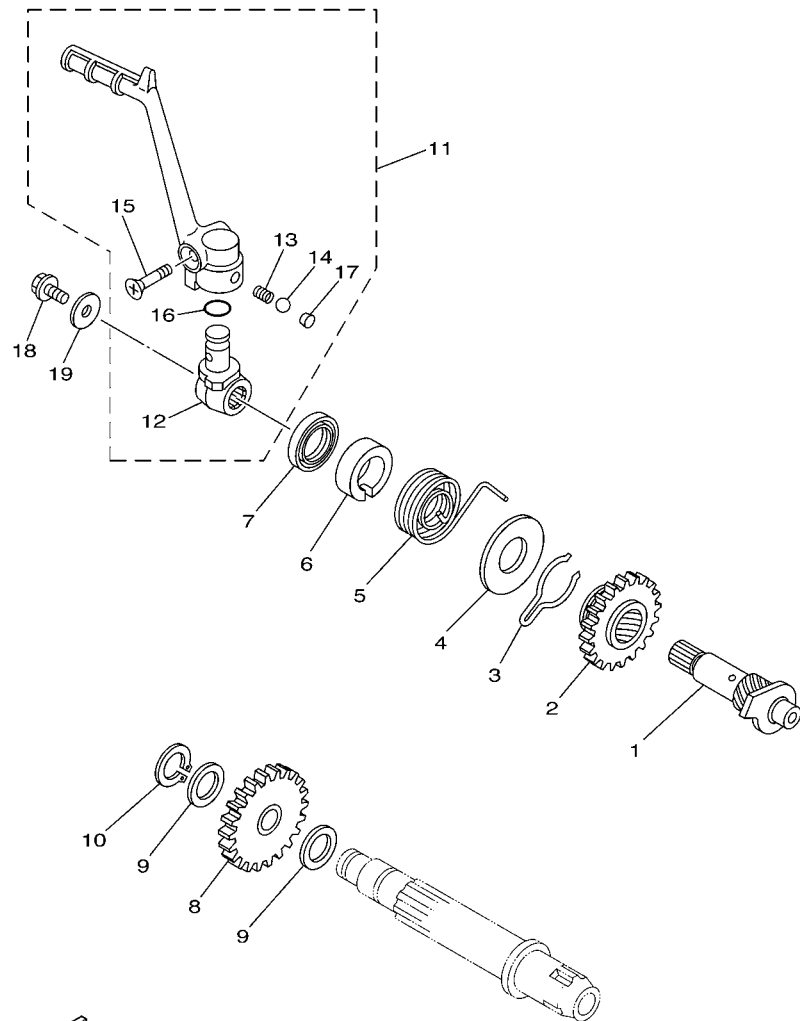


FIG. 9 CRANKCASE COVER 1

REF. NO.	PART NO.	DESCRIPTION	5PAK	5PAM	5SHK	5SHM	REMARKS
1	4ES-15411-00	COVER, CRANKCASE 1	1	1	1	1	
2	98502-06030	SCREW, PAN HEAD	4	4	4	4	
3	5PA-15451-00	GASKET, CRANKCASE COVER 1	1	1	1	1	
4	5PA-15431-00	COVER, CRANKCASE 3	1	1	1	1	
5	4ES-15461-00	GASKET, CRANKCASE COVER 2	1	1	1	1	
6	99530-10014	PIN, DOWEL	2	2	2	2	
7	95022-06030	BOLT, FLANGE	4	4	4	4	
8	95022-06040	BOLT, FLANGE	1	1	1	1	
9	95022-08080	BOLT, FLANGE	1	1	1	1	
10	90430-08119	GASKET	1	1	1	1	
11	3Y1-15363-00	PLUG, OIL	1	1	1	1	
12	93210-19123	O-RING	1	1	1	1	
13	5PA-15415-10	COVER, GENERATOR	1	1	1	1	
14	5PA-15463-00	GASKET, COVER PINION 2	1	1	1	1	
15	99530-08016	PIN, DOWEL	2	2	2	2	
16	95022-06025	BOLT, FLANGE	4	4	4	4	
17	95022-06035	BOLT, FLANGE	2	2	2	2	



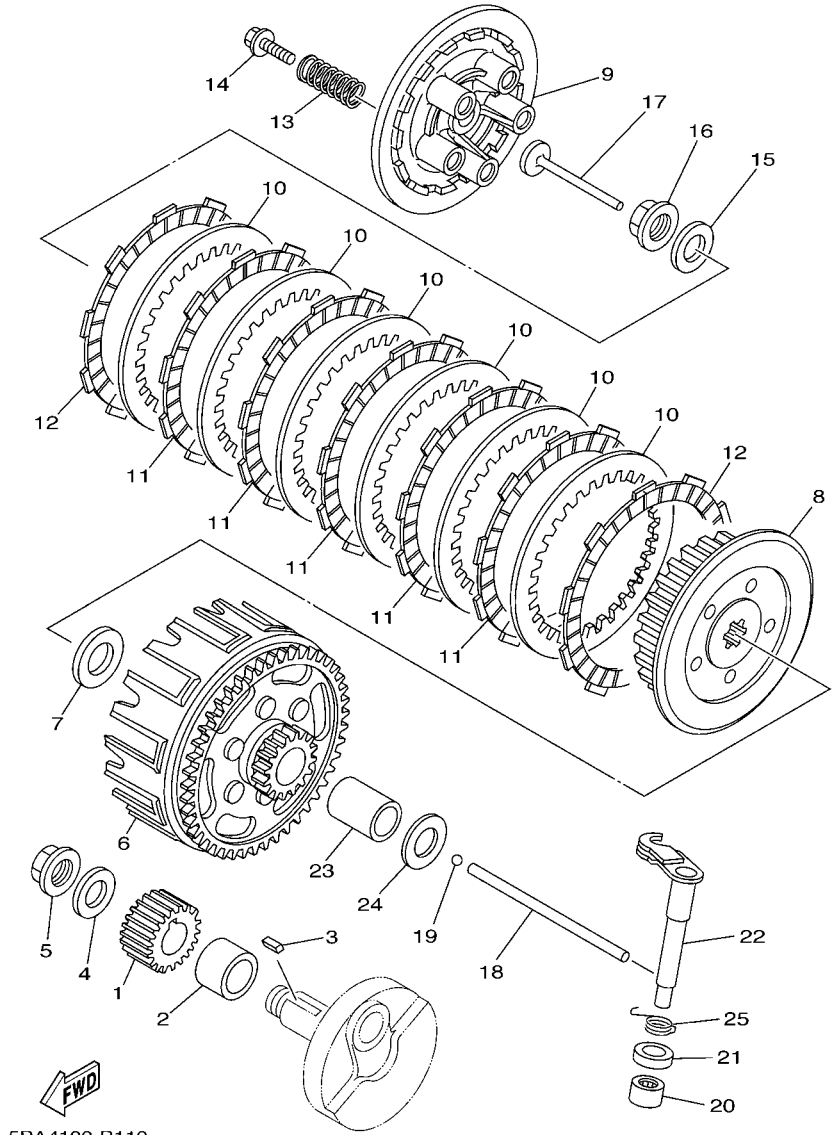
FIG. 10 STARTER



5PA1100-A100

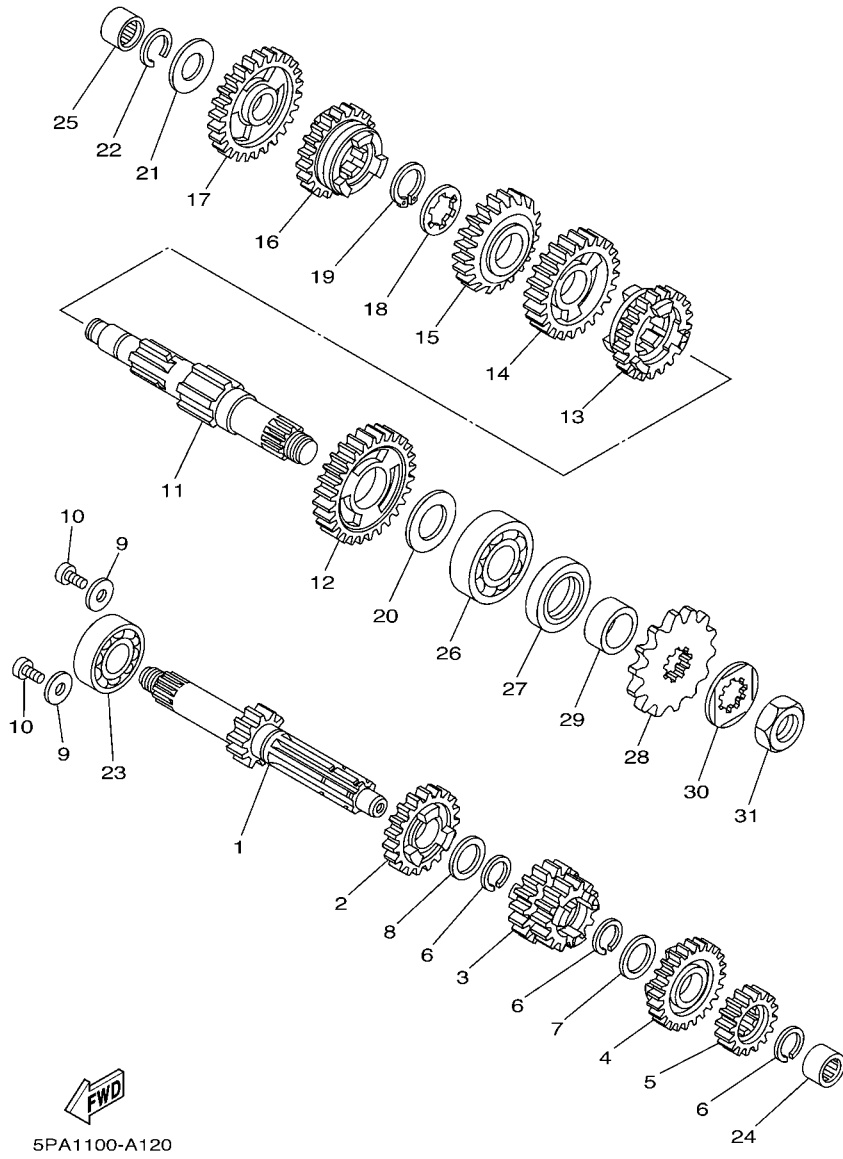
REF. NO.	PART NO.	DESCRIPTION	SPAK	SPAM	SSHK	SSHM	REMARKS
1	5PA-15660-00	KICK AXLE ASSY	1	1	1	1	
2	5PA-15641-00	GEAR, KICK	1	1	1	1	
3	90468-23194	CLIP	1	1	1	1	
4	90201-176L4	WASHER, PLATE	1	1	1	1	
5	90508-26750	SPRING, TORSION	1	1	1	1	
6	4ES-15664-00	GUIDE, SPRING	1	1	1	1	
7	93102-17263	OIL SEAL	1	1	1	1	
8	5PA-15651-00	GEAR, KICK IDLE	1	1	1	1	
9	90201-124F8	WASHER, PLATE	2	2	2	2	
10	99009-12400	CIRCLIP	1	1	1	1	
11	5PA-15620-01	KICK CRANK ASSY	1	1	1	1	
12	5PA-15621-00	.BOSS, KICK CRANK	1	1	1	1	
13	90501-12081	.SPRING, COMPRESSION	1	1	1	1	
14	93507-32009	.BALL	1	1	1	1	
15	90151-06045	.SCREW, COUNTERSUNK	1	1	1	1	
16	93210-12152	.O-RING	1	1	1	1	
17	90336-06031	.PLUG, TAPER	1	1	1	1	
18	95022-06012	BOLT, FLANGE	1	1	1	1	
19	90201-06060	WASHER, PLATE	1	1	1	1	

FIG. 11 CLUTCH



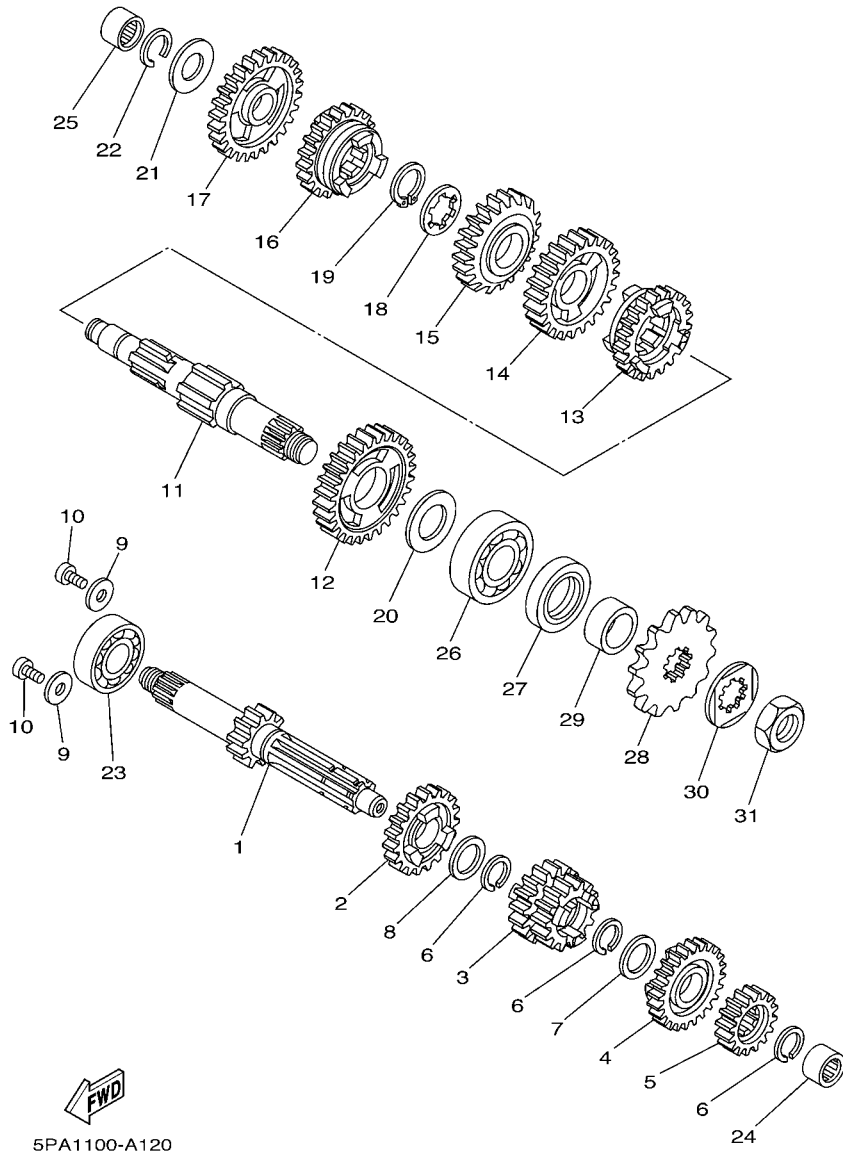
5PA4100-B110

REF. NO.	PART NO.	DESCRIPTION	SPA-K	SPAM	SSH-K	SSH-M	REMARKS
1	5PA-16111-00	GEAR, PRIMARY DRIVE	1	1	1	1	
2	90387-20488	COLLAR	1	1	1	1	
3	90282-05001	KEY, STRAIGHT (5MMX16MM)	1	1	1	1	
4	90208-12015	WASHER, CONICAL SPRING	1	1	1	1	
5	90179-12659	NUT	1	1	1	1	
6	5PA-16150-10	PRIMARY DRIVEN GEAR COMP.	1	1	1	1	
7	90201-17558	WASHER, PLATE	1	1	1	1	
8	5PA-16371-10	BOSS, CLUTCH	1	1	1	1	
9	2TK-16351-00	PLATE, PRESSURE 1	1	1	1	1	
10	131-16324-00	PLATE, CLUTCH 1	6	6	6	6	
11	4ES-16321-00	PLATE, FRICTION	5	5	5	5	
12	21V-16321-00	PLATE, FRICTION	2	2	2	2	
13	90501-204A0	SPRING, COMPRESSION	5	5	5	5	
14	90119-05001	BOLT, WITH WASHER	5	5	5	5	
15	90208-12015	WASHER, CONICAL SPRING	1	1	1	1	
16	90179-12659	NUT	1	1	1	1	
17	4ES-16356-00	ROD, PUSH 1	1	1	1	1	
18	5PA-16357-00	ROD, PUSH 2	1	1	1	1	
19	93503-16003	BALL	1	1	1	1	
20	93315-11206	BEARING	1	1	1	1	
21	93102-12224	OIL SEAL	1	1	1	1	
22	4ES-16381-00	PUSH LEVER COMP.	1	1	1	1	
23	5PA-16181-00	SPACER 1	1	1	1	1	
24	90201-171G6	WASHER, PLATE	1	1	1	1	
25	90508-14016	SPRING, TORSION	1	1	1	1	



**FIG. 12 TRANSMISSION**

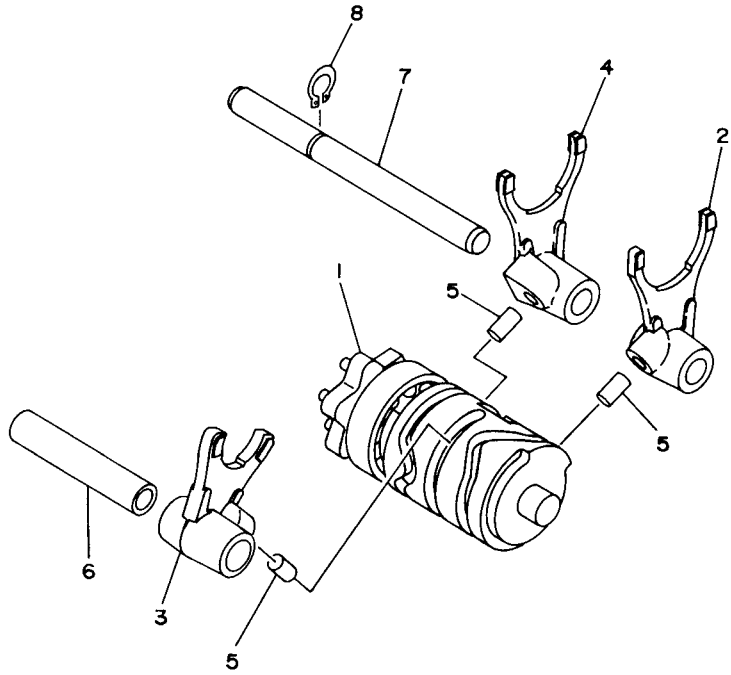
REF. NO.	PART NO.	DESCRIPTION	5PAK	5PAM	5SHK	5SHM	REMARKS
1	5PA-17411-00	AXLE, MAIN (11T)	1	1	1	1	
2	4ES-17151-10	GEAR, 5TH PINION (23T)	1	1	1	1	
3	4ES-17131-03	GEAR, 3RD PINION (17T/17T)	1	1	1	1	
4	4ES-17161-10	GEAR, 6TH PINION (25T)	1	1	1	1	
5	4ES-17121-01	GEAR, 2ND PINION (17T)	1	1	1	1	
6	93440-17064	CIRCLIP	3	3	3	3	
7	90209-14008	WASHER	1	1	1	1	
8	90201-17545	WASHER, PLATE	1	1	1	1	
9	90201-06060	WASHER, PLATE	2	2	2	2	
10	90157-06071	SCREW, PAN HEAD	2	2	2	2	
11	5PA-17421-00	AXLE, DRIVE	1	1	1	1	
12	5PA-17221-00	GEAR, 2ND WHEEL (32T)	1	1	1	1	
13	5PA-17261-00	GEAR, 6TH WHEEL (25T)	1	1	1	1	
14	4ES-17231-10	GEAR, 3RD WHEEL (26T)	1	1	1	1	
15	5PA-17241-00	GEAR, 4TH WHEEL (22T)	1	1	1	1	
16	4ES-17251-00	GEAR, 5TH WHEEL (26T)	1	1	1	1	
17	4ES-17211-01	GEAR, 1ST WHEEL (27T)	1	1	1	1	
18	90209-16209	WASHER	1	1	1	1	
19	93410-20038	CIRCLIP	1	1	1	1	
20	90201-20611	WASHER, PLATE	1	1	1	1	
21	164-17427-00-06	SHIM 1 (T=0.6)	1	1	1	1	UR
	164-17427-00-08	SHIM 1 (T=0.8)	1	1	1	1	UR
	164-17427-00-10	SHIM 1 (T=1.0)	1	1	1	1	UR
22	93440-15012	CIRCLIP	1	1	1	1	
23	93306-20333	BEARING	1	1	1	1	
24	93317-11245	BEARING	1	1	1	1	
25	93315-31502	BEARING	1	1	1	1	



**FIG. 12 TRANSMISSION**

REF. NO.	PART NO.	DESCRIPTION	5PAK	5PAM	5SHK	5SHM	REMARKS
26	93306-20401	BEARING	1	1	1	1	
27	93102-26042	OIL SEAL	1	1	1	1	
28	9382A-14227	SPROCKET, DRIVE (14T)	1	1	1	1	STD
	9382A-15228	SPROCKET, DRIVE (15T)	1	1	1	1	AP
29	90387-202A0	COLLAR	1	1	1	1	
30	90215-20261	WASHER, LOCK	1	1	1	1	
31	90179-16226	NUT	1	1	1	1	

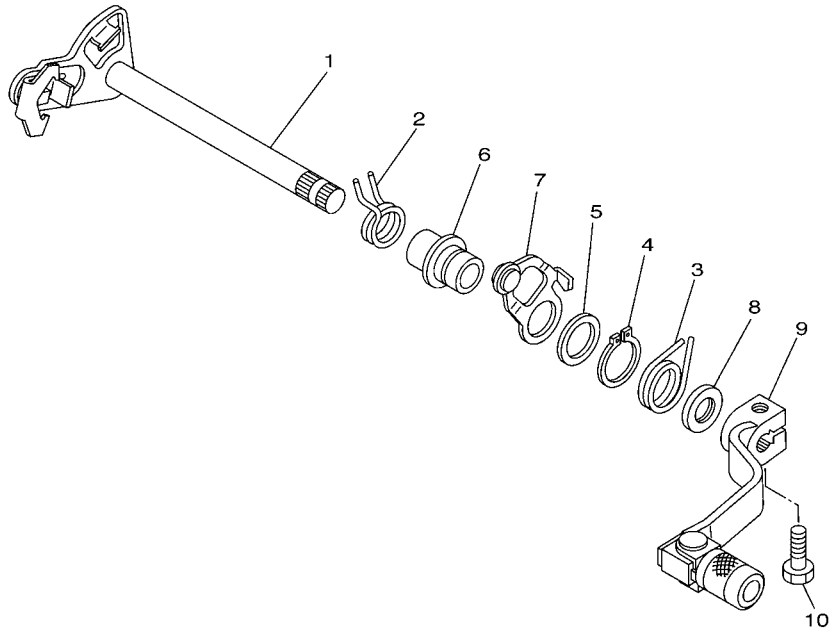
FIG. 13 SHIFT CAM & FORK



4ES3100-4130

REF. NO.	PART NO.	DESCRIPTION	SPAK	SPAM	SSHK	SSHM	REMARKS
1	4ES-18540-00	SHIFT CAM ASSY	1	1	1	1	
2	4ES-18511-02	FORK, SHIFT 1	1	1	1	1	
3	5R2-18512-00	FORK, SHIFT 2	1	1	1	1	
4	4ES-18513-01	FORK, SHIFT 3	1	1	1	1	
5	90250-06013	PIN, STRAIGHT	3	3	3	3	
6	4BA-18531-00	BAR, SHIFT FORK GUIDE 1	1	1	1	1	
7	4BA-18535-00	BAR, SHIFT FORK GUIDE 2	1	1	1	1	
8	99009-10400	CIRCLIP	1	1	1	1	

FIG. 14 SHIFT SHAFT

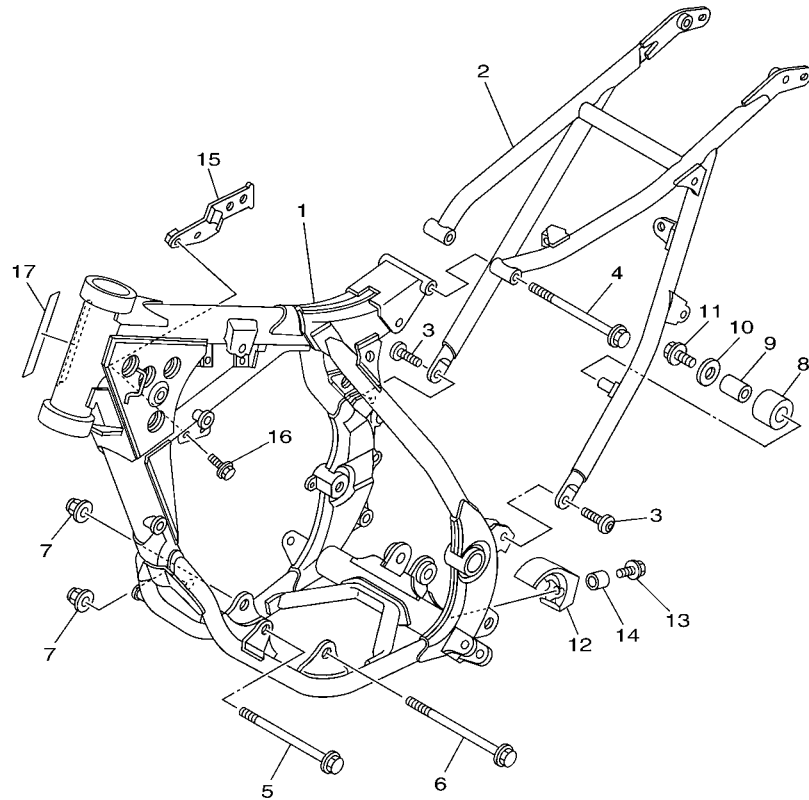


REF. NO.	PART NO.	DESCRIPTION	5PAK	5PAM	5SHK	5SHM	REMARKS
1	5PA-18101-00	SHIFT SHAFT ASSY	1	1	1	1	
2	90508-32016	SPRING, TORSION	1	1	1	1	
3	90508-24007	SPRING, TORSION	1	1	1	1	
4	99009-17400	CIRCLIP	1	1	1	1	
5	90201-177G4	WASHER, PLATE	1	1	1	1	
6	5PA-1811E-00	COLLAR,SHIFT PEDAL	1	1	1	1	
7	5PA-18140-00	STOPPER LEVER ASSY	1	1	1	1	
8	93101-12173	OIL SEAL	1	1	1	1	
9	2HF-18110-02	SHIFT PEDAL ASSY	1	1	1	1	
10	97022-06020	BOLT	1	1	1	1	



5PA1100-A140

FIG. 15 FRAME

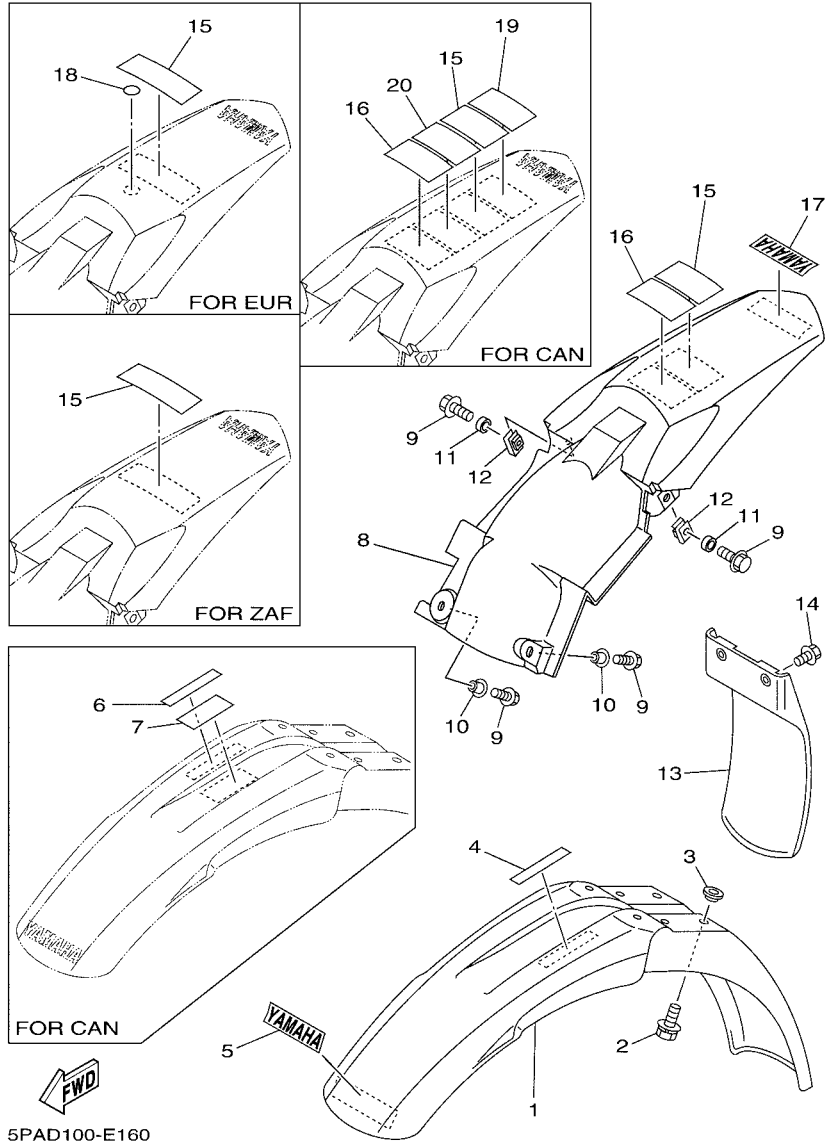


REF. NO.	PART NO.	DESCRIPTION	5PAK	5PAM	5SHK	5SHM	REMARKS
1	5PA-21101-11-33	FRONT FRAME COMP.	1	1	1	1	YB FOR DPBSE
2	5PA-21190-00-33	REAR FRAME COMP.	1	1	1	1	YB FOR DPBSE
3	90110-08096	BOLT, HEXAGON SOCKET HEAD	2	2	2	2	
4	95817-08125	BOLT, FLANGE	1	1	1	1	
5	90105-10111	BOLT, FLANGE	1	1	1	1	
6	90105-10110	BOLT, FLANGE	1	1	1	1	
7	95607-10200	NUT, U FLANGE	2	2	2	2	
8	30X-22178-00	TENSIONER	1	1	1	1	
9	4V4-22184-00	BUSH	1	1	1	1	
10	90201-081R9	WASHER, PLATE	1	1	1	1	
11	95027-08012	BOLT, FLANGE	1	1	1	1	
12	4ES-22178-00	TENSIONER	1	1	1	1	
13	90119-06118	BOLT, WITH WASHER	1	1	1	1	
14	90387-067K6	COLLAR	1	1	1	1	
15	5PA-21274-00	BRACKET, C.D.I. UNIT	1	1	1	1	
16	95027-06012	BOLT, FLANGE	2	2	2	2	
17	3HA-24141-00	PROTECTOR, FUEL TANK	1	1	1	1	



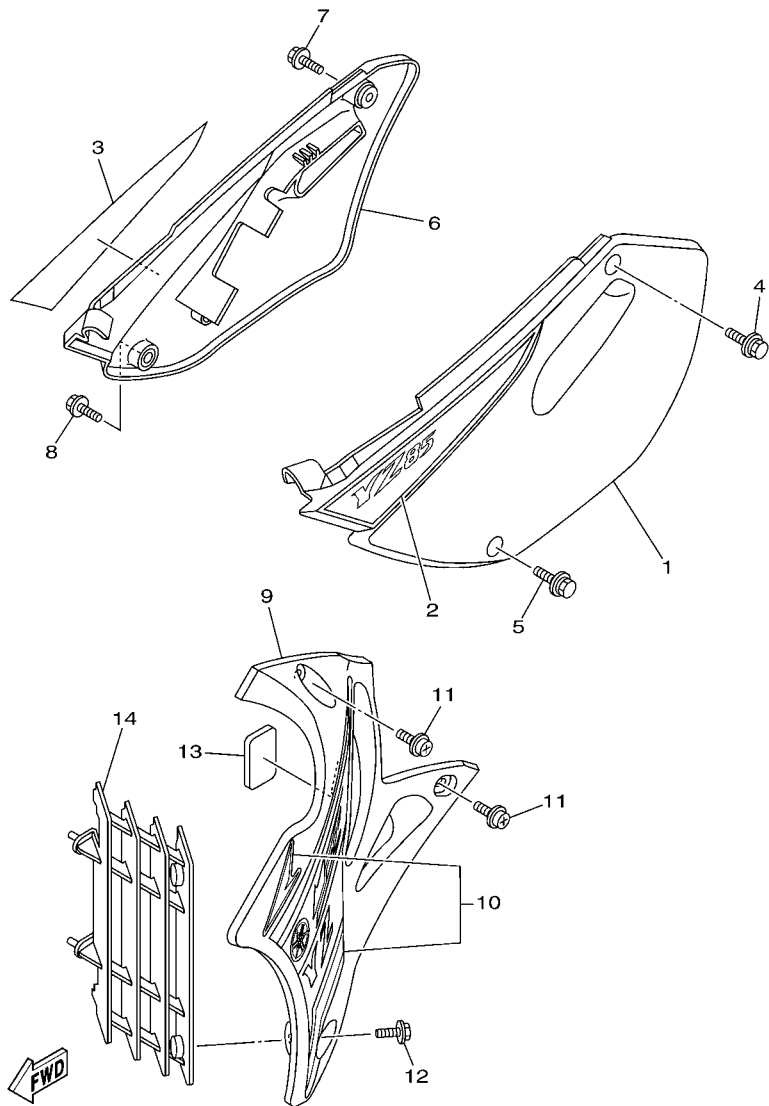
5PAK100-G150

FIG. 16 FENDER



REF. NO.	PART NO.	DESCRIPTION	SPAK	SPAM	SSHK	SSHM	REMARKS
1	4ES-21511-20	FENDER, FRONT	1	1	1	1	
2	90119-06063	BOLT, WITH WASHER	4	4	4	4	
3	90209-06187	WASHER	4	4	4	4	
4	3XJ-2415E-A1	LABEL, CAUTION	1				EXCEPT FOR CAN
	3XJ-2415E-C1	LABEL, CAUTION		1		1	FOR JPN
5	4ES-2153E-01	EMBLEM, YAMAHA	1	1	1	1	
6	3XJ-2415E-B1	LABEL, CAUTION	1				FOR CAN
7	4SR-2416E-00	LABEL, CAUTION CANADA	1				FOR CAN
8	5PA-21611-00	FENDER, REAR	1	1	1	1	
9	90119-06192	BOLT, WITH WASHER	4	4	4	4	
10	90387-064X4	COLLAR	2	2	2	2	
11	90387-0701A	COLLAR	2	2	2	2	
12	90183-06023	NUT, SPRING	2	2	2	2	
13	4ES-21642-00	GUARD, FLAP	1	1	1	1	
14	90119-06185	BOLT, WITH WASHER	2	2	2	2	
15	5PA-2118K-00	LABEL, CAUTION	1				EXCEPT EUR,ZAF
	5PA-21568-00	LABEL, WARNING	1		1		FOR EUR,ZAF
	5PA-2118K-20	LABEL, CAUTION		1		1	FOR JPN
16	3XJ-2151H-A1	LABEL 5	1				EXCEPT EUR,ZAF
	4LB-2151H-02	LABEL 5		1		1	FOR JPN
17	4ES-2153E-01	EMBLEM, YAMAHA	1	1	1	1	
18	3ME-2415E-01	LABEL, CAUTION	1		1		FOR EUR
19	5PA-2118K-10	LABEL, CAUTION	1				FOR CAN
20	3XJ-2151H-B1	LABEL 5	1				FOR CAN

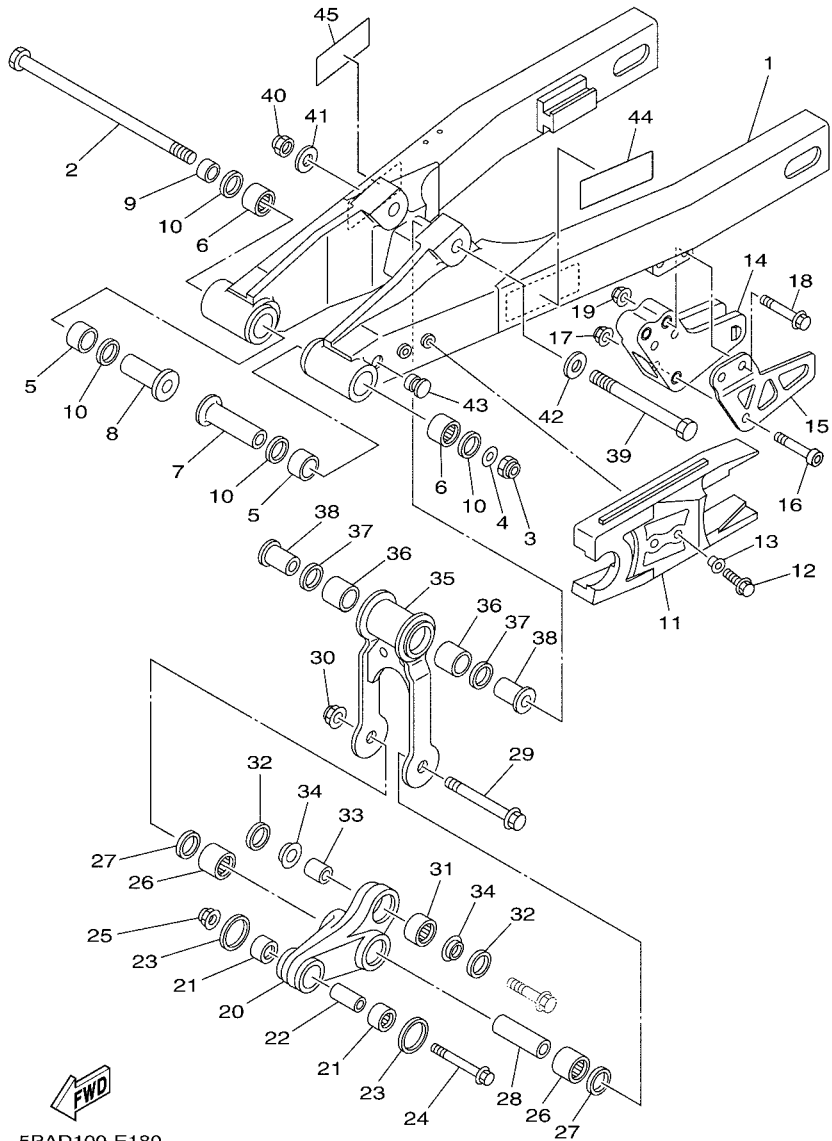




5PAK100-G170

FIG. 17 SIDE COVER

REF. NO.	PART NO.	DESCRIPTION	5PAK	5PAM	5SHK	5SHM	REMARKS
1	5PA-21711-00	COVER, SIDE 1	1	1	1	1	
2	5PA-2173E-20	GRAPHIC 1	1	1	1	1	
3	5PA-2173F-20	GRAPHIC 2	1	1	1	1	
4	90119-06225	BOLT, WITH WASHER	1	1	1	1	
5	90119-06001	BOLT, WITH WASHER	1	1	1	1	
6	5PA-21721-00	COVER, SIDE 2	1	1	1	1	
7	90119-06225	BOLT, WITH WASHER	1	1	1	1	
8	90119-06001	BOLT, WITH WASHER	1	1	1	1	
9	5PA-21731-00	COVER, SIDE 3	1	1	1	1	
10	5PA-24230-00	GRAPHIC SET	1	1	1	1	
11	90159-06182	SCREW, WITH WASHER	2	2	2	2	
12	90159-06078	SCREW, WITH WASHER	1	1	1	1	
13	1FK-21746-00	DAMPER	1	1	1	1	
14	5PH-2172A-10	PANEL 1	1	1	1	1	



5PAD100-E180

FIG. 18 REAR ARM

REF. NO.	PART NO.	DESCRIPTION	5PAK	5PAM	5SHK	5SHM	REMARKS
1	5PA-22110-00	REAR ARM COMP.	1	1			
	5SH-22110-10	REAR ARM COMP.			1	1	
2	22W-25181-01	AXLE, WHEEL	1	1	1	1	
3	95617-12100	NUT, U	1	1	1	1	
4	90201-124G9	WASHER, PLATE	1	1	1	1	
5	90385-17042	BUSH	2	2	2	2	
6	93317-21746	BEARING	2	2	2	2	
7	90387-127J8	COLLAR	1	1	1	1	
8	90387-127J7	COLLAR	1	1	1	1	
9	90387-1200U	COLLAR	1	1	1	1	
10	93109-17071	OIL SEAL	4	4	4	4	
11	5PA-22151-00	SEAL, GUARD	1	1	1	1	
12	95027-06014	BOLT, FLANGE	2	2	2	2	
13	90387-062X0	COLLAR	2	2	2	2	
14	5PA-22199-00	SUPPORT, CHAIN	1	1	1	1	
15	5PA-22128-00	COVER, THRUST 1	1	1	1	1	
16	92017-06040	BOLT, BUTTON HEAD	1	1	1	1	
17	95607-06200	NUT, SELF U-FLANGE	1	1	1	1	
18	95027-08050	BOLT, FLANGE	2	2	2	2	
19	95607-08200	NUT, SELF-LOCKING	2	2	2	2	
20	5PA-2217A-00	ARM, RELAY	1	1	1	1	
21	93315-21455	BEARING	2	2	2	2	
22	90380-10218	BUSH, SOLID	1	1	1	1	
23	4ES-22129-00	COVER, THRUST 2	2	2	2	2	
24	90105-10582	BOLT, FLANGE	1	1	1	1	
25	95607-10200	NUT, U FLANGE	1	1	1	1	
26	93317-31771	BEARING	2	2	2	2	

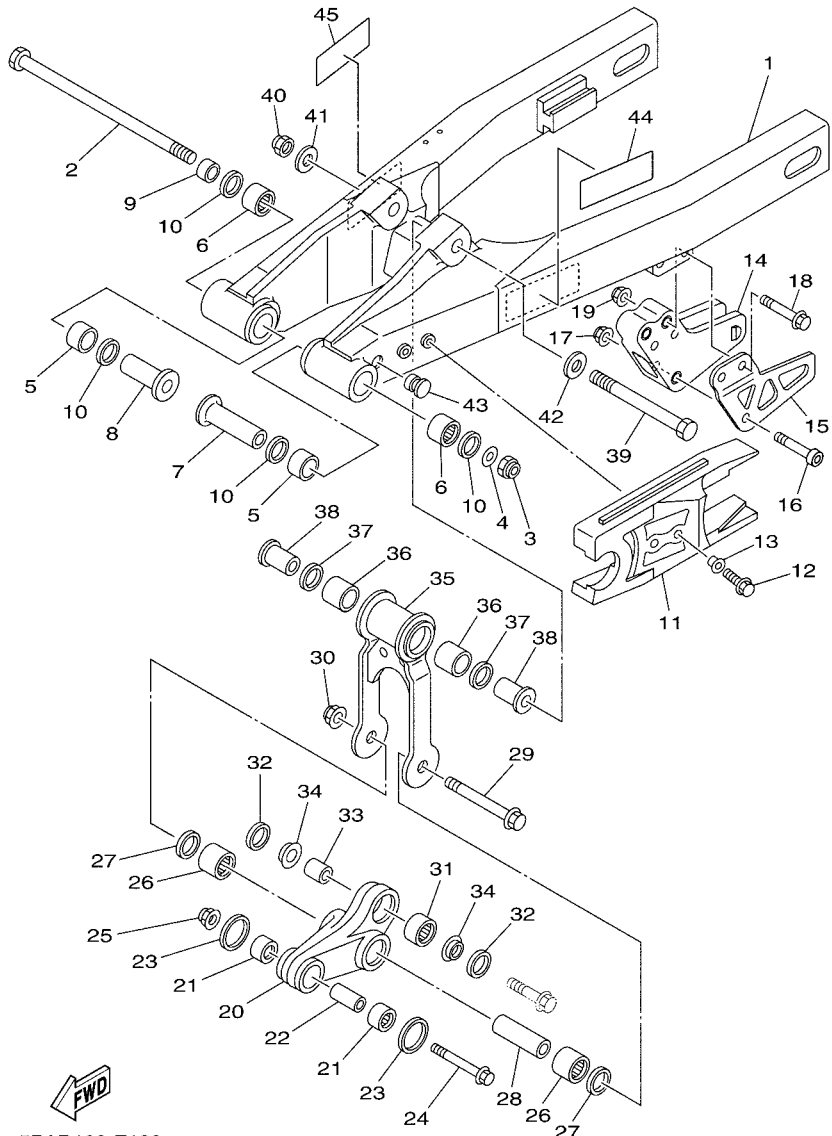
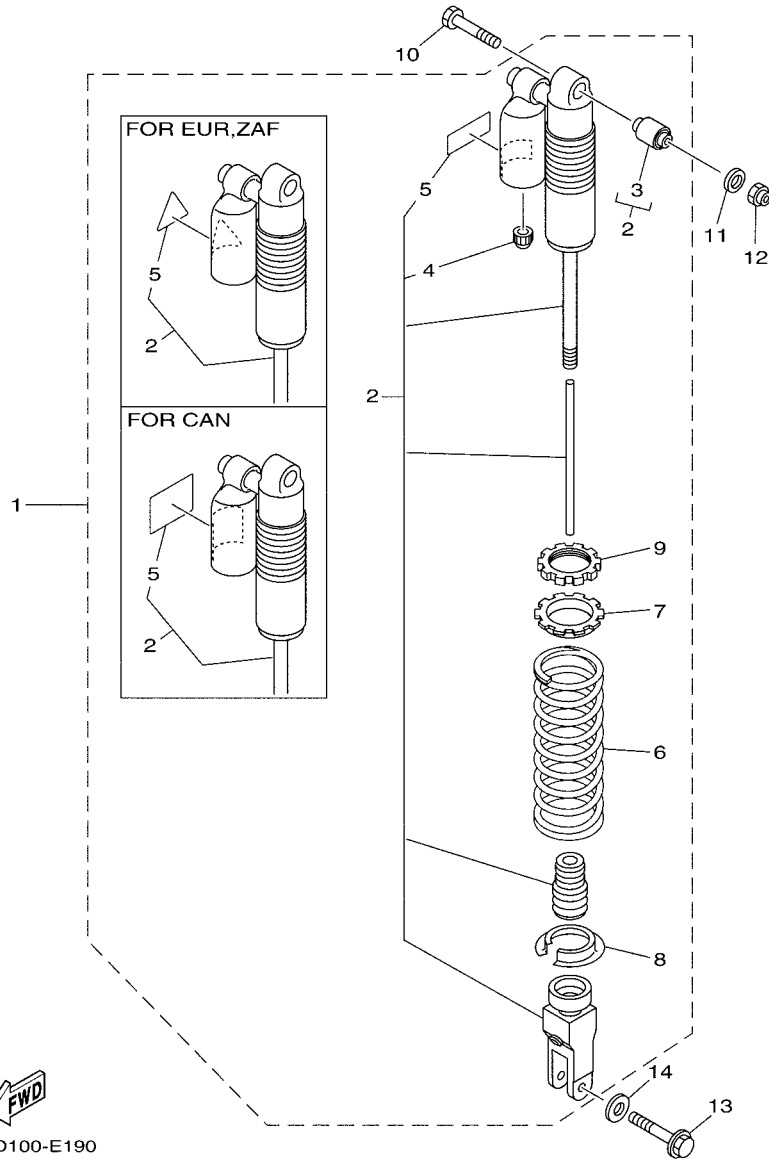


FIG. 18 REAR ARM

REF. NO.	PART NO.	DESCRIPTION	SPAK	SPAM	SSHK	SSHM	REMARKS
27	93101-17062	OIL SEAL	2	2	2	2	
28	90380-12219	BUSH, SOLID	1	1	1	1	
29	90105-12382	BOLT, FLANGE	1	1	1	1	
30	95607-12200	NUT, SELF-LOCKING	1	1	1	1	
31	5PA-22176-00	BEARING	1	1	1	1	
32	5PA-22475-00	SEAL, DUST	2	2	2	2	
33	5PA-22184-00	BUSH	1	1	1	1	
34	5PA-22253-00	COLLAR, DISTANCE	2	2	2	2	
35	4ES-2217F-00	ROD, CONNECTING 1	1	1	1	1	
36	93317-31771	BEARING	2	2	2	2	
37	93101-17062	OIL SEAL	2	2	2	2	
38	90381-12091	BUSH, SOLID	2	2	2	2	
39	90101-12755	BOLT	1	1	1	1	
40	90185-12119	NUT, SELF-LOCKING	1	1	1	1	
41	90201-12749	WASHER, PLATE	1	1	1	1	
42	90201-127J6	WASHER, PLATE	1	1	1	1	
43	90338-10150	PLUG	2	2	2	2	
44	3RV-21668-A0	LABEL, TIRE	1	1			
45	3RV-21668-B0	LABEL, TIRE	1				FOR CAN

FIG. 19 REAR SUSPENSION



5PAD100-E190

REF. NO.	PART NO.	DESCRIPTION	5PAK	5PAM	5SHK	5SHM	REMARKS
1	5PA-22210-50	SHOCK ABSORBER ASSY, REAR	1				UR FOR USA
	5PA-22210-60	SHOCK ABSORBER ASSY, REAR	1				UR FOR EUR
	5PA-22210-80	SHOCK ABSORBER ASSY, REAR	1				UR FOR CAN
	5PA-22210-90	SHOCK ABSORBER ASSY, REAR	1				UR FOR ZAF
	5PA-22210-70	SHOCK ABSORBER ASSY, REAR		1			FOR JPN
---	5SH-22210-40	SHOCK ABSORBER ASSY, REAR			1		UR FOR EUR
	5SH-22210-30	SHOCK ABSORBER ASSY, REAR			1		UR FOR ZAF
	5SH-22210-50	SHOCK ABSORBER ASSY, REAR				1	FOR JPN
2	5PA-22201-50	.DAMPER SUB ASSY	1				UR FOR USA
	5PA-22201-60	.DAMPER SUB ASSY	1				UR FOR EUR
---	5PA-22201-80	.DAMPER SUB ASSY	1				UR FOR CAN
	5PA-22201-90	.DAMPER SUB ASSY	1				UR FOR ZAF
---	5PA-22201-70	.DAMPER SUB ASSY		1			FOR JPN
	5SH-22201-40	.DAMPER SUB ASSY			1		UR FOR EUR
---	5SH-22201-30	.DAMPER SUB ASSY			1		UR FOR ZAF
	5SH-22201-50	.DAMPER SUB ASSY				1	FOR JPN
3	4ES-22216-00	..BUSH, REAR SHOCK ABSORBER	1	1	1	1	
4	58T-23184-L0	..CAP, AIR VALVE	1	1	1	1	
5	4AA-22259-80	..LABEL, WARNING	1				UR FOR USA
	4AA-22259-60	..LABEL, WARNING	1				UR FOR CAN
---	4AA-22259-40	..LABEL, WARNING	1		1		UR FOR EUR,ZAF
	4AA-22259-50	..LABEL, WARNING		1		1	FOR JPN
6	4ES-22212-K0	.SPRING (K=45N/MM)	1				UR FOR EUR
	4ES-22212-F0	.SPRING (K=49N/MM)	1	1			UR EXCEPT FOR EUR
	4ES-22212-G0	.SPRING (K=47N/MM)			1		UR FOR EUR
	4ES-22212-H0	.SPRING (K=51N/MM)			1	1	UR FOR ZAF,JPN
7	4ES-22214-00	.GUIDE, SPRING 1	1	1	1	1	

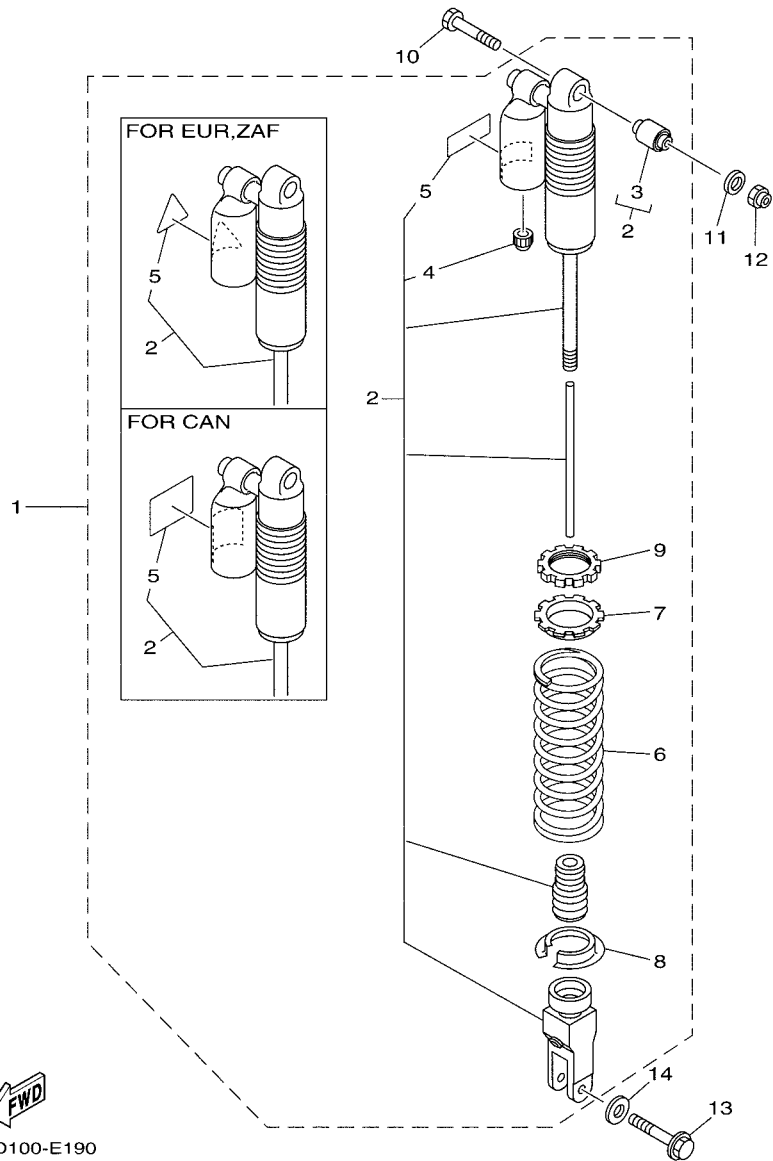
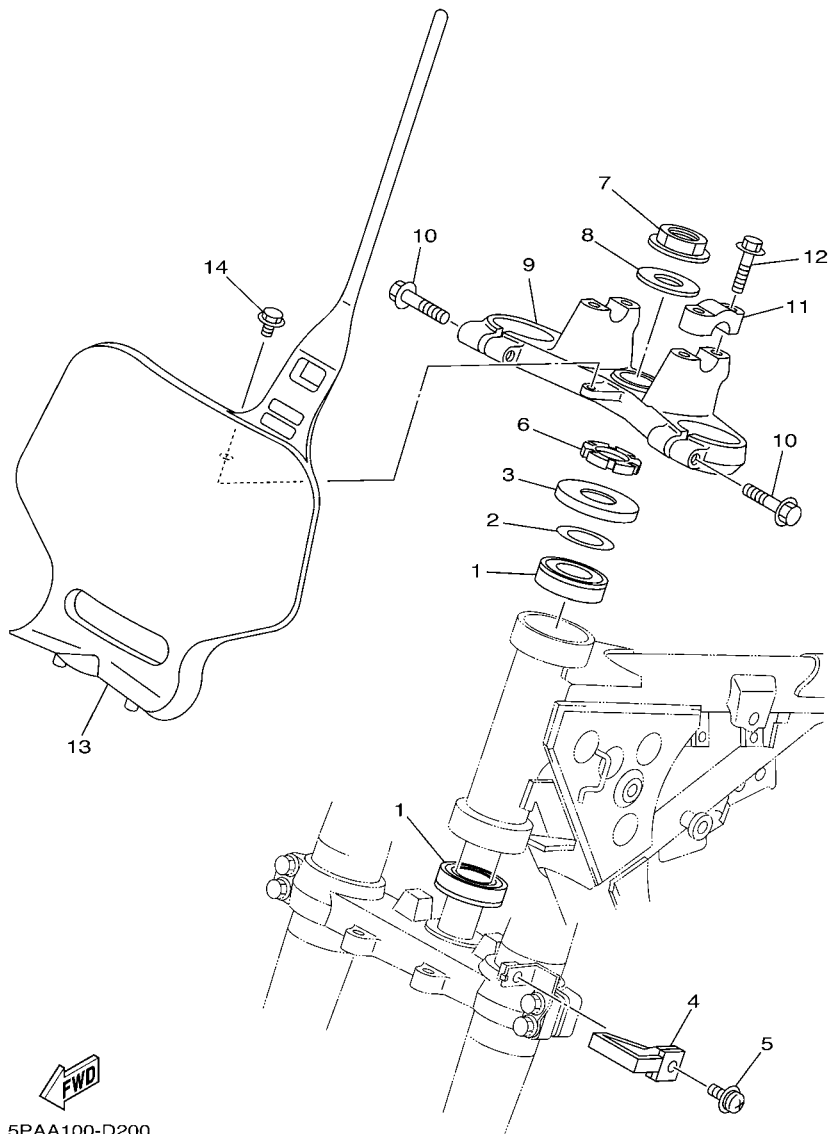


FIG. 19 REAR SUSPENSION

REF. NO.	PART NO.	DESCRIPTION	SPAK	SPAM	SSHK	SSHM	REMARKS
8	3JD-22214-00	.GUIDE, SPRING 1	1	1	1	1	
9	4ES-22251-00	.NUT 1	1	1	1	1	
10	90109-10729	BOLT	1	1	1	1	
11	92907-10600	WASHER, PLATE	1	1	1	1	
12	90185-10110	NUT, SELF-LOCKING	1	1	1	1	
13	90105-10614	BOLT, FLANGE	1	1	1	1	
14	90201-112U6	WASHER, PLATE	1	1	1	1	

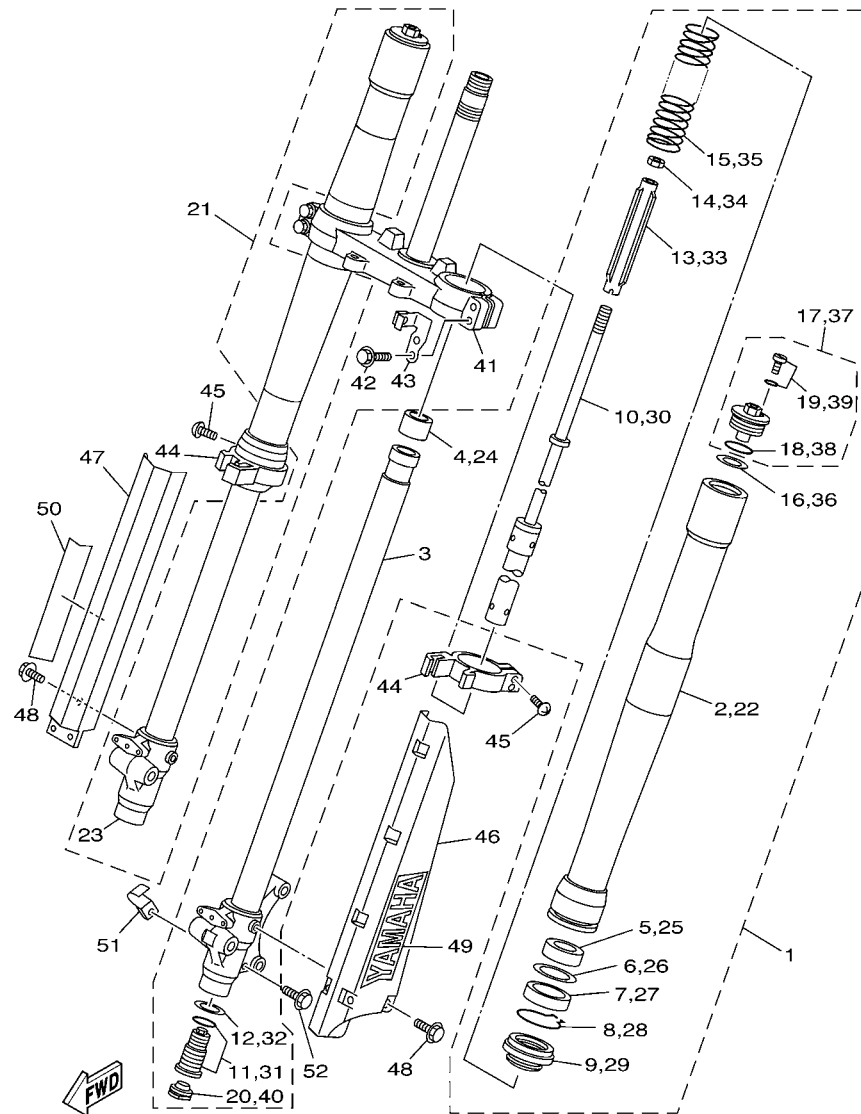
C10



**FWD**  
5PAA100-D200

**FIG. 20 STEERING**

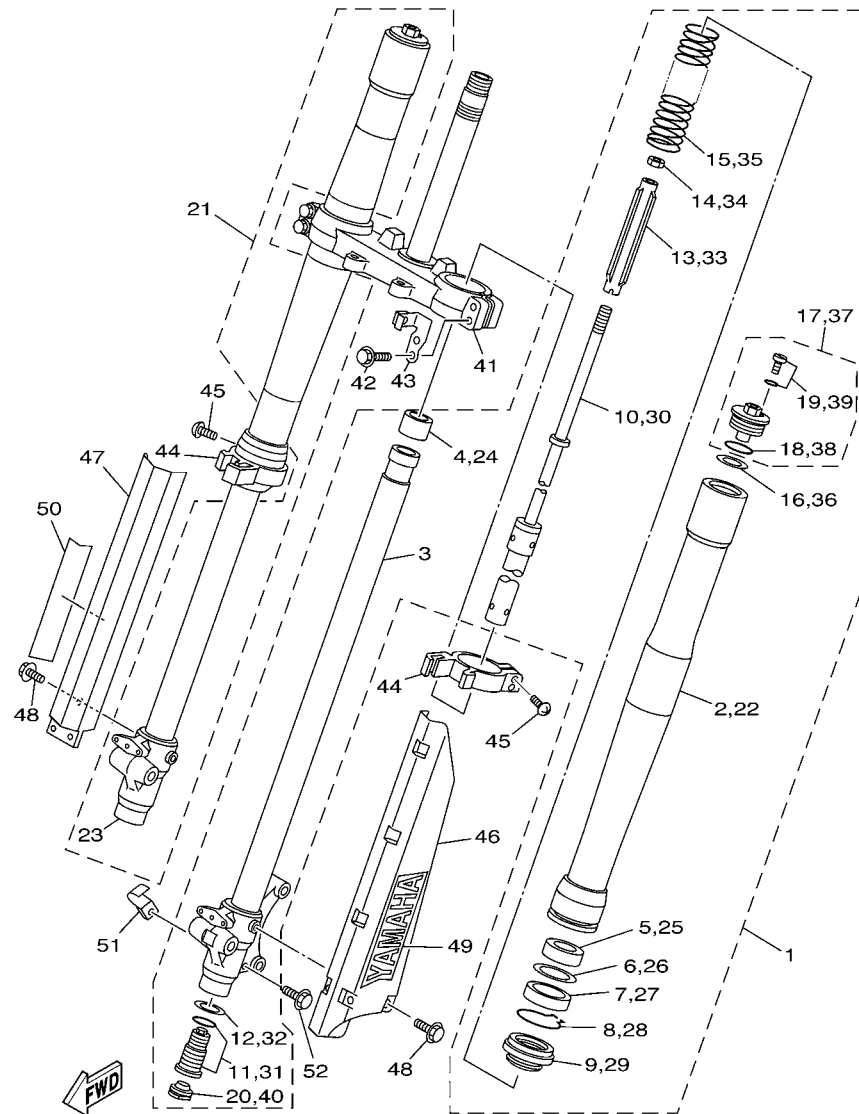
REF. NO.	PART NO.	DESCRIPTION	9PAK	9PAM	5SHK	5SHM	REMARKS
1	93332-00079	BEARING	2	2	2	2	
2	90201-256K5	WASHER, PLATE (0.5T)	1	1	1	1	
3	1J7-23415-00	COVER, BALL RACE 1	1	1	1	1	
4	4DA-23389-00	GUIDE, CABLE	1	1	1	1	
5	90157-05079	SCREW, PAN HEAD	1	1	1	1	
6	90179-25033	NUT	1	1	1	1	
7	90179-22412	NUT	1	1	1	1	
8	90201-220T0	WASHER, PLATE	1	1	1	1	
9	4ES-23435-00	CROWN, HANDLE	1	1	1	1	
10	95807-08035	BOLT, FLANGE	2	2	2	2	
11	3SP-23441-00	HOLDER, HANDLE UPPER	2	2	2	2	
12	95027-08030	BOLT, FLANGE	4	4	4	4	
13	4ES-23485-00	PLATE, NUMBER	1	1	1	1	
14	95027-06012	BOLT, FLANGE	1	1	1	1	



5PA7100-C210

FIG. 21 FRONT FORK

REF. NO.	PART NO.	DESCRIPTION	5PAK	5PAM	5SHK	5SHM	REMARKS
1	5PA-23102-10	FRONT FORK ASSY (L.H)	1	1			
	5SH-23102-10	FRONT FORK ASSY (L.H)			1	1	
2	5PA-23136-10	.TUBE, OUTER (RIGHT)	1	1	1	1	
3	5PA-23120-00	.INNER TUBE COMP.2	1	1	1	1	
4	5PA-23171-00	.PISTON, FRONT FORK	1	1	1	1	
5	5PA-23125-00	.METAL, SLIDE 1	1	1	1	1	
6	5K5-23149-00	.WASHER, SPRING UPPER	1	1	1	1	
7	4ES-23145-00	.OIL SEAL	1	1	1	1	
8	4A1-23156-00	.CLIP, OIL SEAL	1	1	1	1	
9	4ES-23144-00	.SEAL, DUST	1	1	1	1	
10	5PA-23170-00	.CYLINDER COMP., FRONT FORK	1	1	1	1	
11	5PA-2316A-00	.VALVE COMP.	1	1			
	5SH-2316A-00	.VALVE COMP.			1	1	
12	2HH-23158-L0	.GASKET	1	1	1	1	
13	4ES-23142-00	.SEAT, SPRING UPPER	1	1	1	1	
14	3XJ-23357-L0	.NUT	1	1	1	1	
15	4ES-23141-40	.SPRING, FRONT FORK(K=2.8N/MM)	1	1			
	4LB-23141-10	.SPRING, FRONT FORK(K=2.9N/MM)			1	1	
16	5PA-23149-00	.WASHER, SPRING UPPER	1	1	1	1	
17	4ES-23111-10	.BOLT, CAP	1	1	1	1	
18	4V4-23188-L0	.O-RING	1	1	1	1	
19	3JD-23394-00	.BOLT, SPECIAL	1	1	1	1	
20	3JD-2312G-L0	.PLUG	1	1	1	1	
21	5PA-23103-10	FRONT FORK ASSY (R.H)	1	1			
	5SH-23103-10	FRONT FORK ASSY (R.H)			1	1	
22	5PA-23136-10	.TUBE, OUTER (RIGHT)	1	1	1	1	
23	5PA-23110-00	.INNER TUBE COMP.1	1	1	1	1	



5PA7100-C210

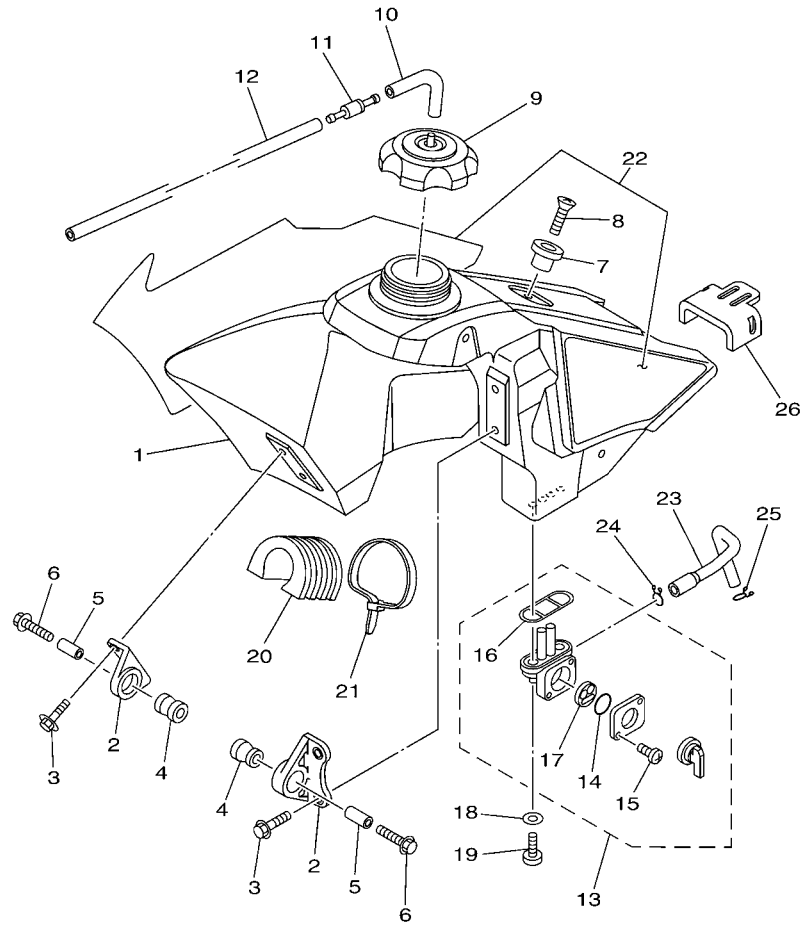
FIG. 21 FRONT FORK

REF. NO.	PART NO.	DESCRIPTION	SPA-K	SPA-M	SSH-K	SSH-M	REMARKS
24	5PA-23171-00	.PISTON, FRONT FORK	1	1	1	1	
25	5PA-23125-00	.METAL, SLIDE 1	1	1	1	1	
26	5K5-23149-00	.WASHER, SPRING UPPER	1	1	1	1	
27	4ES-23145-00	.OIL SEAL	1	1	1	1	
28	4A1-23156-00	.CLIP, OIL SEAL	1	1	1	1	
29	4ES-23144-00	.SEAL, DUST	1	1	1	1	
30	5PA-23170-00	.CYLINDER COMP., FRONT FORK	1	1	1	1	
31	5PA-2316A-00	.VALVE COMP.	1	1			
	5SH-2316A-00	.VALVE COMP.			1	1	
32	2HH-23158-L0	.GASKET	1	1	1	1	
33	4ES-23142-00	.SEAT, SPRING UPPER	1	1	1	1	
34	3XJ-23357-L0	.NUT	1	1	1	1	
35	4ES-23141-40	.SPRING, FRONT FORK(K=2.8N/MM)	1	1			
	4LB-23141-10	.SPRING, FRONT FORK(K=2.9N/MM)			1	1	
36	5PA-23149-00	.WASHER, SPRING UPPER	1	1	1	1	
37	4ES-23111-10	.BOLT, CAP	1	1	1	1	
38	4V4-23188-L0	.O-RING	1	1	1	1	
39	3JD-23394-00	.BOLT, SPECIAL	1	1	1	1	
40	3JD-2312G-L0	.PLUG	1	1	1	1	
41	5PA-23340-01	UNDER BRACKET COMP.	1	1	1	1	
42	5NY-23346-L0	BOLT 1	4	4	4	4	
43	5PA-2331E-00	GUIDE, CABLE	1	1	1	1	
44	4ES-2314F-00	PROTECTOR GUIDE COMP., 1	2	2	2	2	
45	4V4-23194-L0	SCREW, BOOT BAND	4	4	4	4	
46	5PA-2314H-L0	PROTECTOR COMP., 1	1	1	1	1	
47	5PA-2314J-L0	PROTECTOR COMP., 2	1	1	1	1	
48	95024-06010	BOLT, FLANGE	6	6	6	6	





FIG. 22 FUEL TANK

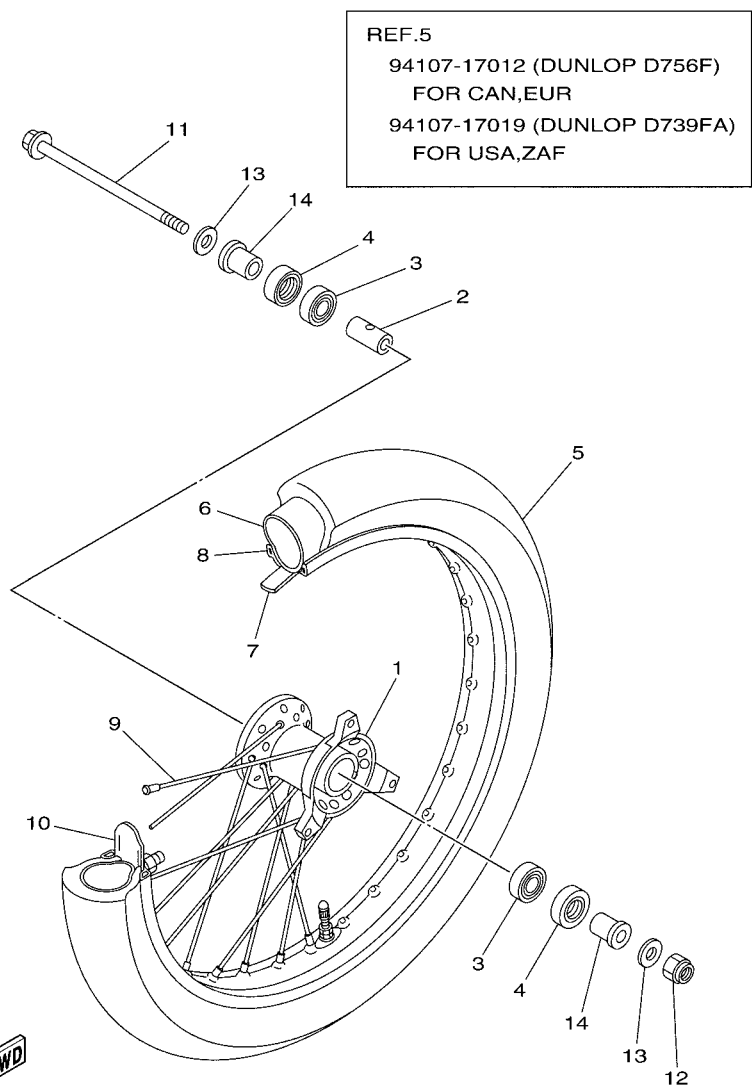


5PAK100-G220

REF. NO.	PART NO.	DESCRIPTION	5PAK	5PAM	5SHK	5SHM	REMARKS
1	5PA-24110-30	FUEL TANK COMP.	1	1	1	1	
2	5XE-24144-00	HOLDER, DAMPER	2	2	2	2	
3	95027-06016	BOLT, FLANGE	4	4	4	4	
4	90480-18549	GROMMET	2	2	2	2	
5	90387-06027	COLLAR	2	2	2	2	
6	90119-06190	BOLT, WITH WASHER	2	2	2	2	
7	4EW-2412F-00	BRACKET, SEAT	1	1	1	1	
8	98707-06025	SCREW, FLAT HEAD	1	1	1	1	
9	5NY-24610-00	CAP ASSY	1	1	1	1	
10	90445-09220	HOSE (L30)	1	1	1	1	
11	3XJ-24380-00	PIPE JOINT ASSY	1	1	1	1	
12	90445-09300	HOSE (L355)	1	1	1	1	
13	4DP-24500-01	FUEL COCK ASSY 1	1	1	1	1	
14	3AJ-24534-01	.SEAL, COCK	1	1	1	1	
15	98507-03008	.SCREW, PAN HEAD	2	2	2	2	
16	4X8-24512-00	.O-RING	1	1	1	1	
17	3AC-24523-00	.VALVE PACKING	1	1	1	1	
18	90202-05193	WASHER, PLATE	2	2	2	2	
19	90149-06011	SCREW	2	2	2	2	
20	5PA-24182-00	DAMPER, LOCATING 2	1	1	1	1	
21	90465-13275	CLAMP	1	1	1	1	
22	5PA-24240-60	GRAPHIC SET	1	1	1	1	
23	5PA-24311-00	PIPE, FUEL 1	1	1	1	1	
24	90467-10008	CLIP	1	1	1	1	
25	90467-09002	CLIP	1	1	1	1	
26	5PA-24181-00	DAMPER, LOCATING 1	1	1	1	1	

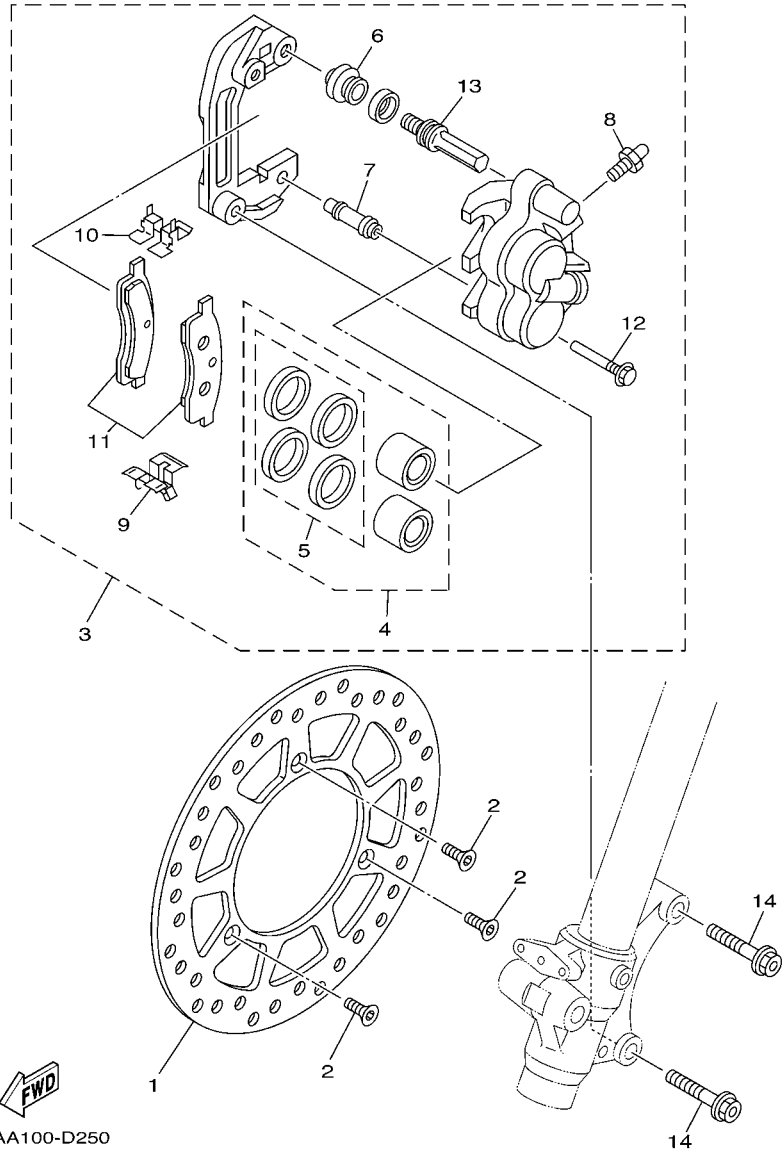


FIG. 24 FRONT WHEEL



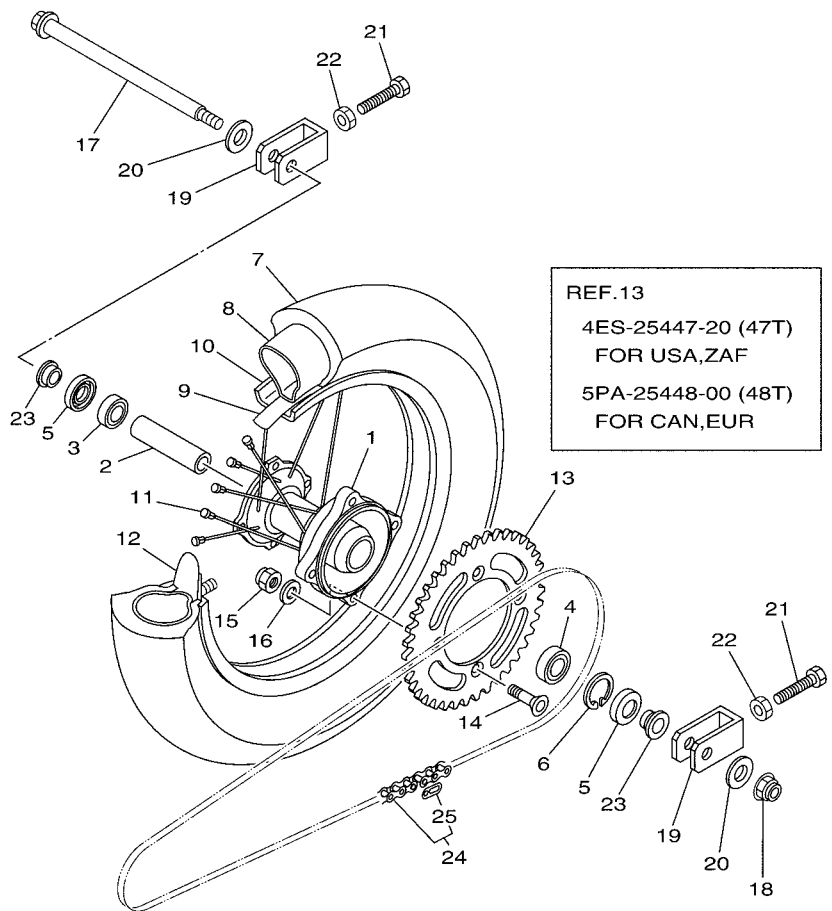
REF. NO.	PART NO.	DESCRIPTION	SPAK	SPAM	SSHK	SSHM	REMARKS
1	4ES-25111-00	HUB, FRONT	1	1	1	1	
2	90387-124H0	COLLAR	1	1	1	1	
3	93306-20120	BEARING	2	2	2	2	
4	93106-20031	OIL SEAL	2	2	2	2	
5	94107-17012	TIRE (70/100-17 40M D756F)	1				UR DUNLOP
	94107-17019	TIRE (70/100-17 40M D739FA)	1	1			UR DUNLOP
	94107-19015	TIRE (70/100-19 42M D756F)			1		UR FOR EUR DUNLOP
	94107-19012	TIRE (70/100-19 42M D739FA)			1	1	UR FOR ZAF DUNLOP
6	94207-17284	TUBE (70/100-17M/C TR4)	1	1			DUNLOP
	94207-19290	TUBE (70/100-19M/C TR4)			1	1	DUNLOP
7	94307-17166	BAND, RIM (80/90,70/100-17)	1	1			DUNLOP
	94307-19170	BAND, RIM (70/100-19)			1	1	DUNLOP
8	94414-17530	RIM (1.40-17)	1	1			
	94414-19521	RIM (1.40-19)			1	1	
9	4ES-25104-20	SPOKE SET, FRONT	1	1			
	4LB-25104-00	SPOKE SET, FRONT			1	1	
10	1T1-25194-00	SPACER, BEAD	1	1	1	1	
11	4ES-25181-00	AXLE, WHEEL	1	1	1	1	
12	90185-12046	NUT, SELF-LOCKING	1	1	1	1	
13	90201-12362	WASHER, PLATE	2	2	2	2	
14	4ES-25183-10	COLLAR, WHEEL	2	2	2	2	

**FIG. 25 FRONT BRAKE CALIPER**



REF. NO.	PART NO.	DESCRIPTION	5PAK	5PAM	5SHK	5SHM	REMARKS
1	5PA-2582T-00	DISC, BRAKE (LEFT)	1	1	1	1	
2	90149-06327	SCREW	3	3	3	3	
3	5PA-2580T-00	CALIPER ASSY (LEFT)	1	1	1	1	
4	4ES-W0057-10	.PISTON ASSY, CALIPER	1	1	1	1	
5	4ES-W0047-10	..CALIPER SEAL KIT	1	1	1	1	
6	5R2-25937-00	.BOOT 2	1	1	1	1	
7	56A-25937-00	.BOOT 2	1	1	1	1	
8	51L-W0048-00	.BLEED SCREW KIT	1	1	1	1	
9	56A-25919-00	.SUPPORT, PAD	1	1	1	1	
10	56A-25919-10	.SUPPORT, PAD	1	1	1	1	
11	5PA-W0045-00	.BRAKE PAD KIT	1	1	1	1	
12	56A-25926-00	.BOLT	1	1	1	1	
13	34X-25914-00	.PIN, SLIDE	1	1	1	1	
14	90105-08211	BOLT, FLANGE	2	2	2	2	

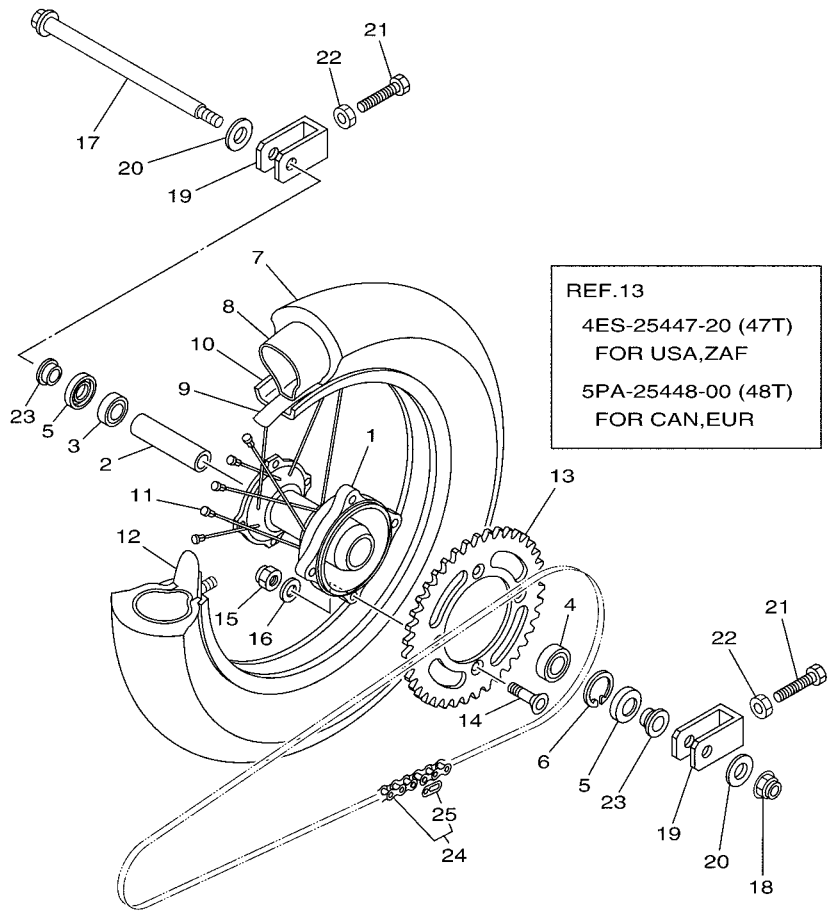
FIG. 26 REAR WHEEL



5PAD100-E260

REF. NO.	PART NO.	DESCRIPTION	SPAK	SPAM	SSHK	SSHM	REMARKS
1	4ES-25311-00	HUB, REAR	1	1	1	1	
2	4ES-25383-00	COLLAR, WHEEL	1	1	1	1	
3	93306-00203	BEARING	1	1	1	1	
4	93306-20203	BEARING	1	1	1	1	
5	93102-20009	OIL SEAL	2	2	2	2	
6	99009-35500	CIRCLIP	1	1	1	1	
7	94109-14012	TIRE (90/100-14 49M D756)	1				DUNLOP
	94109-14015	TIRE (90/100-14 49M D739)		1			DUNLOP
	94109-16015	TIRE (90/100-16 52M D756)			1		DUNLOP
	94109-16012	TIRE (90/100-16 52M D739)				1	DUNLOP
8	94208-14285	TUBE (80-90/100-14M/C TR4)	1	1			DUNLOP
	94209-16291	TUBE (90/100-16M/C TR4)			1	1	DUNLOP
9	94308-14165	BAND, RIM (80-90/100-14)	1	1			DUNLOP
	94307-16171	BAND, RIM (70-90/100-16)			1	1	DUNLOP
10	94416-14529	RIM (1.60-14)	1	1			
	94418-16522	RIM (1.85-16)			1	1	
11	4ES-25304-20	SPOKE SET, REAR	1	1			
	4LB-25304-00	SPOKE SET, REAR			1	1	
12	5X2-25394-00	SPACER, BEAD	1	1			
	1T2-25394-00	SPACER, BEAD			1	1	
13	4ES-25447-20	SPROCKET, DRIVEN (47T)	1	1			UR STD AFAM
	5PA-25448-00	SPROCKET, DRIVEN (48T)	1				UR STD
	5PA-25446-00	SPROCKET, DRIVEN (46T)	1	1			AP
	5PA-25448-00	SPROCKET, DRIVEN (48T)	1	1			AP
	5PA-25449-00	SPROCKET, DRIVEN (49T)	1				AP
	5PA-25452-00	SPROCKET, DRIVEN (52T)			1	1	STD
	5PA-25451-00	SPROCKET, DRIVEN (51T)			1	1	AP

FIG. 26 REAR WHEEL



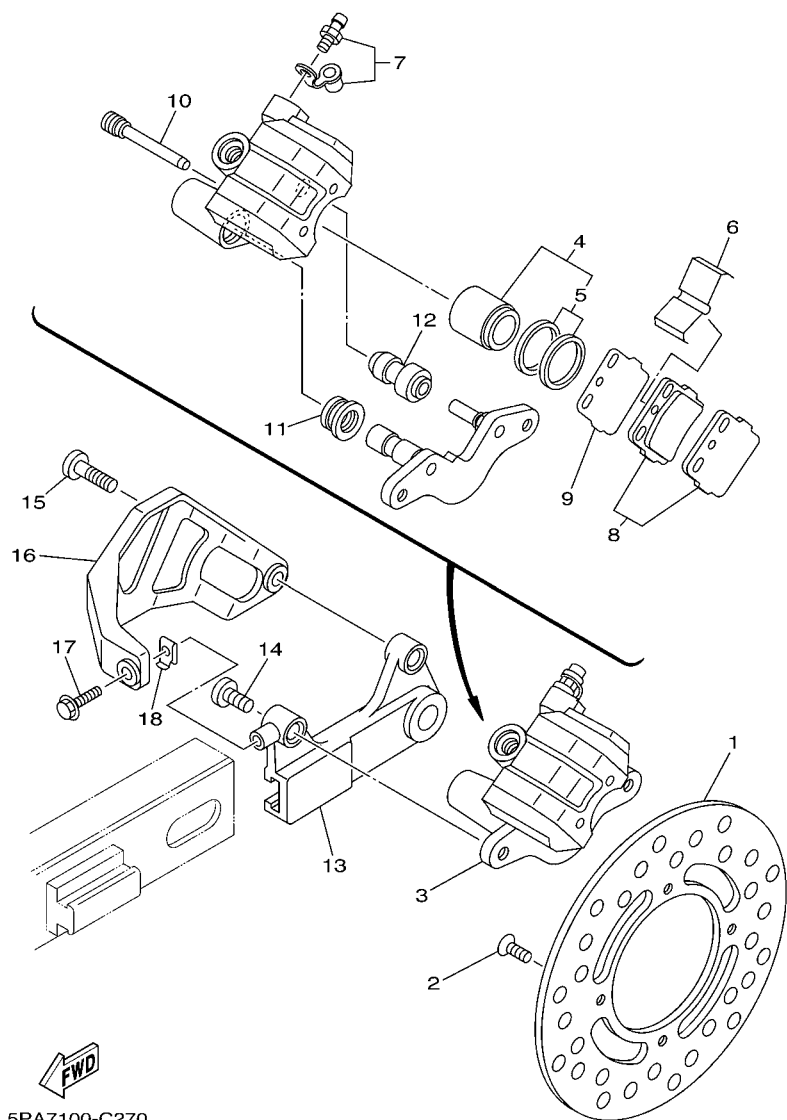
REF.13  
 4ES-25447-20 (47T)  
 FOR USA,ZAF  
 5PA-25448-00 (48T)  
 FOR CAN,EUR



5PAD100-E260

REF. NO.	PART NO.	DESCRIPTION	5PAK	5PAM	5SHK	5SHM	REMARKS
13	5PA-25453-00	SPROCKET, DRIVEN (53T)			1	1	AP
14	90109-081G2	BOLT	4	4	4	4	
15	90185-08169	NUT, SELF-LOCKING	4	4	4	4	
16	90201-086P8	WASHER, PLATE	4	4	4	4	
17	4ES-25381-01	AXLE, WHEEL	1	1	1	1	
18	90185-14142	NUT, SELF-LOCKING	1	1	1	1	
19	5PA-25388-00	PULLER, CHAIN 1	2	2	2	2	
20	90201-152L7	WASHER, PLATE	2	2	2	2	
21	90101-08475	BOLT	2	2	2	2	
22	95307-08700	NUT	2	2	2	2	
23	4ES-25383-10	COLLAR, WHEEL	2	2	2	2	
24	9Y582-00117	CHAIN (DID 428DS 118L)	1	1			
	9Y582-00123	CHAIN (DID 428DS 124L)			1	1	
25	94682-00001	.JOINT,CHAIN (DID 428DS-RJ)	1	1	1	1	

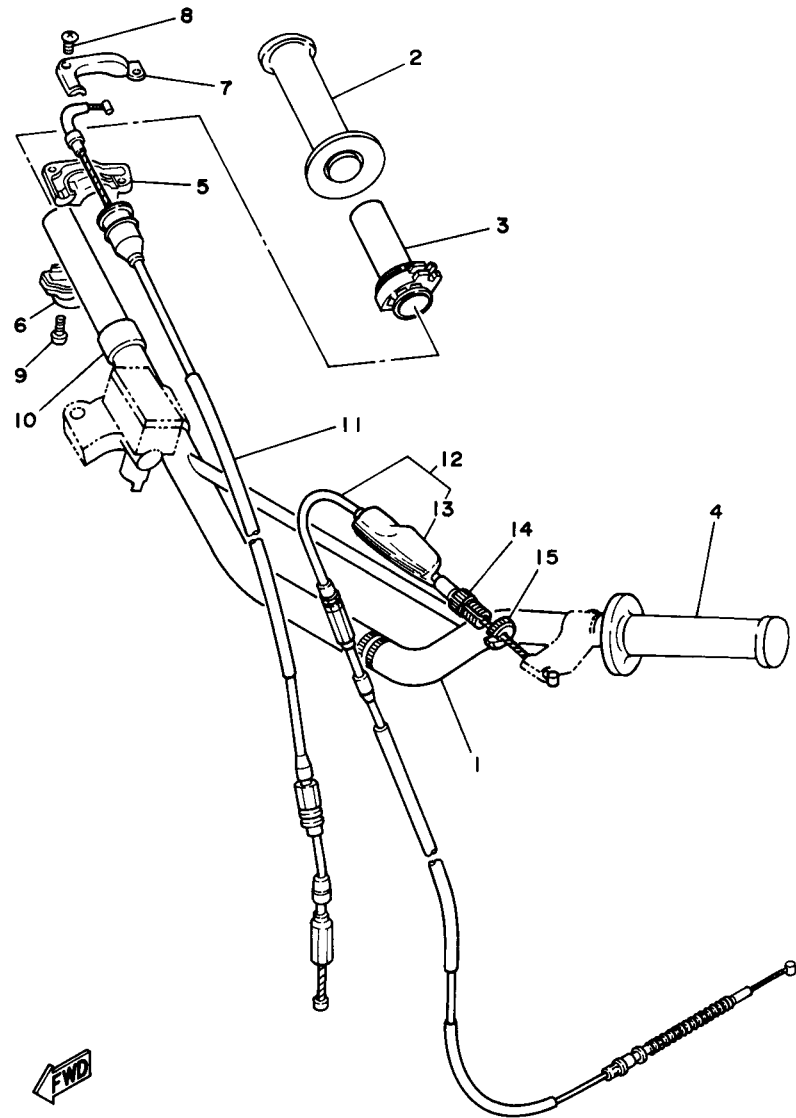
FIG. 27 REAR BRAKE CALIPER



5PA7100-C270

REF. NO.	PART NO.	DESCRIPTION	5PAK	5PAM	5SHK	5SHM	REMARKS
1	5PA-2582W-00	DISK, REAR BRAKE 2	1	1	1	1	
2	90149-06327	SCREW	4	4	4	4	
3	5PA-2580W-00	CALIPER ASSY, REAR 2	1	1	1	1	
4	4EW-W0057-50	.PISTON ASSY, CALIPER	1	1	1	1	
5	4ES-W0047-00	..CALIPER SEAL KIT	1	1	1	1	
6	1UY-25919-51	.SUPPORT, PAD	1	1	1	1	
7	1UY-W0048-50	.BLEED SCREW KIT	1	1	1	1	
8	5PA-W0046-50	.BRAKE PAD KIT 2	1	1	1	1	
9	3GD-25827-00	.SHIM, CALIPER	1	1	1	1	
10	3GD-25933-00	.PIN, PAD	2	2	2	2	
11	1UY-25917-51	.BOOT, CALIPER	1	1	1	1	
12	1UY-25937-51	.BOOT 2	1	1	1	1	
13	4ES-25920-00	SUPT. BRKT. ASSY.	1	1	1	1	
14	90110-08096	BOLT, HEXAGON SOCKET HEAD	1	1	1	1	
15	90109-08718	BOLT	1	1	1	1	
16	4ES-27491-00	PROTECTOR	1	1	1	1	
17	90105-06078	BOLT, FLANGE	1	1	1	1	
18	4ES-27114-00	STOPPER, MAIN STAND	1	1	1	1	



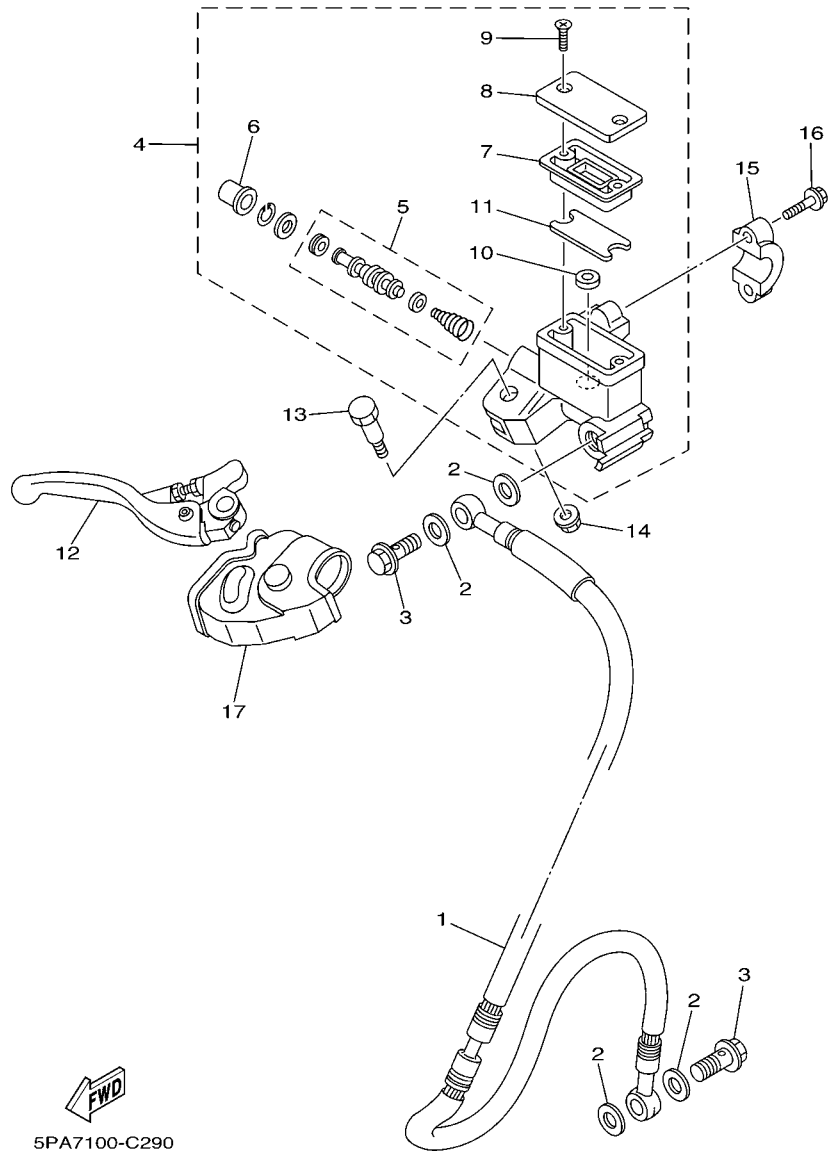


4ES6100-7280

FIG. 28 STEERING HANDLE & CABLE

REF. NO.	PART NO.	DESCRIPTION	SPAK	SPAM	SSHK	SSHM	REMARKS
1	5PA-26111-00	HANDLEBAR	1	1	1	1	
2	4GY-26242-00	GRIP (RIGHT)	1	1	1	1	
3	22W-26243-00	TUBE, THROTTLE GUIDE	1	1	1	1	
4	4GY-26241-00	GRIP	1	1	1	1	
5	5X2-26281-00	CAP, GRIP UPPER	1	1	1	1	
6	322-26282-00	CAP, GRIP LOWER	1	1	1	1	
7	5X2-2628H-01	CAP, WIRE	1	1	1	1	
8	98707-04012	SCREW, FLAT HEAD	2	2	2	2	
9	98507-05016	SCREW, PAN HEAD	2	2	2	2	
10	90387-227H7	COLLAR	1	1	1	1	
11	5PA-26311-00	CABLE, THROTTLE 1	1	1	1	1	
12	4ES-26335-11	CABLE, CLUTCH	1	1	1	1	
13	498-26372-00	.COVER, HANDLE LEVER 1	1	1	1	1	
14	90123-08046	BOLT	1	1	1	1	
15	90179-08148	NUT	1	1	1	1	

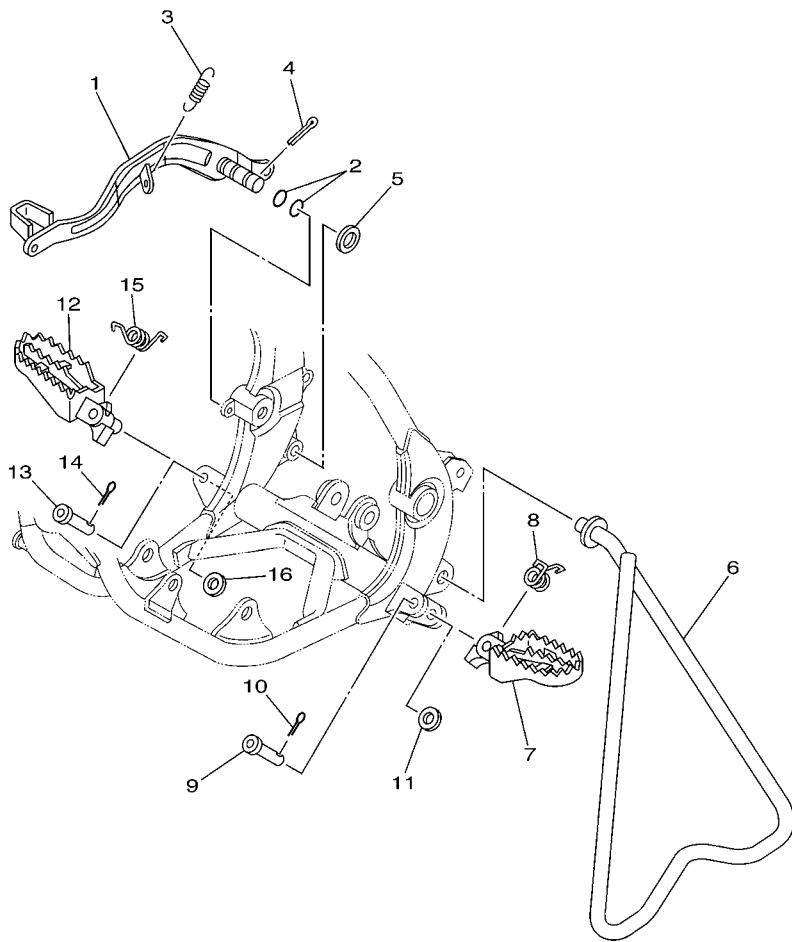
FIG. 29 FRONT MASTER CYLINDER



5PA7100-C290

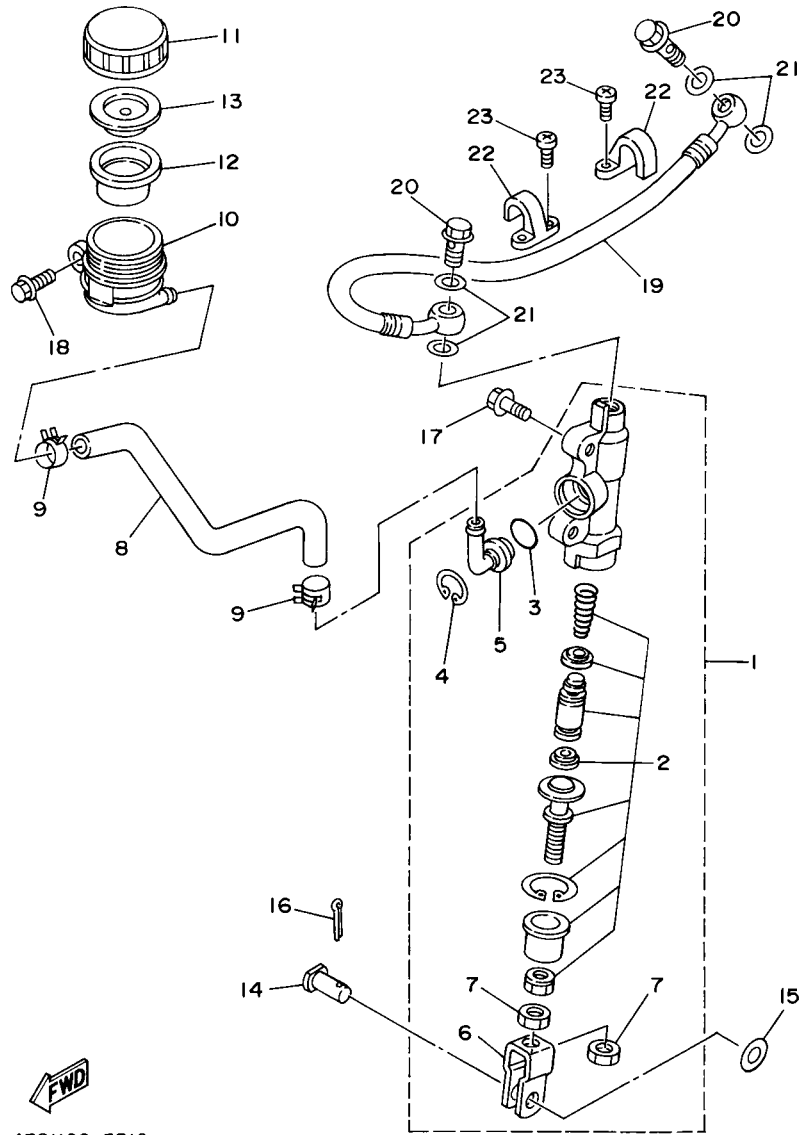
REF. NO.	PART NO.	DESCRIPTION	5PAK	5PAM	5SHK	5SHM	REMARKS
1	4ES-25872-11	HOSE, BRAKE 1	1	1			
	5SH-25872-01	HOSE, BRAKE 1			1	1	
2	90201-10118	WASHER, PLATE	4	4	4	4	
3	90401-10168	BOLT, UNION	2	2	2	2	
4	5XE-W2587-00	MASTER CYLINDER SUB ASSY	1	1	1	1	
5	5NY-W0041-00	.CYLINDER KIT, MASTER	1	1	1	1	
6	5NY-25868-00	.BOOT, MASTER CYLINDER	1	1	1	1	
7	5XE-25854-00	.DIAPHRAGM, RESERVOIR	1	1	1	1	
8	5MV-25852-01	.CAP, RESERVOIR	1	1	1	1	
9	98706-04012	.SCREW, FLAT HEAD	2	2	2	2	
10	5CG-25715-00	.SEPARATOR ASSY	1	1	1	1	
11	5XE-25853-00	.FLOAT, RESERVOIR	1	1	1	1	
12	5MV-83922-00	LEVER 2	1	1	1	1	
13	5MV-2589F-00	BOLT, LEVER	1	1	1	1	
14	95701-06500	NUT, WITH WASHER	1	1	1	1	
15	5MV-25867-00	BRACKET, MASTER CYLINDER	1	1	1	1	
16	5MV-25833-00	BOLT, FITTING	2	2	2	2	
17	5NY-26372-00	COVER, HANDLE LEVER 1	1	1	1	1	

FIG. 30 STAND & FOOTREST



**FWD**  
5PA1100-A300

REF. NO.	PART NO.	DESCRIPTION	SPAK	SPAM	SSHK	SSHM	REMARKS
1	5PA-27211-00	PEDAL, BRAKE	1	1	1	1	
2	93210-11073	O-RING	2	2	2	2	
3	90506-15480	SPRING, TENSION	1	1	1	1	
4	91401-20025	PIN, COTTER	1	1	1	1	
5	90201-15700	WASHER, PLATE	1	1	1	1	
6	5PA-27311-00	STAND, SIDE	1	1			
	5SH-27311-00	STAND, SIDE			1	1	
7	5ET-27411-00	FOOTREST 1	1	1	1	1	
8	90508-282B8	SPRING, TORSION	1	1	1	1	
9	90240-10004	PIN, CLEVIS	1	1	1	1	
10	91401-25015	PIN, COTTER	1	1	1	1	
11	90201-10119	WASHER, PLATE	1	1	1	1	
12	5ET-27421-00	FOOTREST 2	1	1	1	1	
13	90240-10004	PIN, CLEVIS	1	1	1	1	
14	91401-25015	PIN, COTTER	1	1	1	1	
15	90508-282B9	SPRING, TORSION	1	1	1	1	
16	90201-10119	WASHER, PLATE	1	1	1	1	

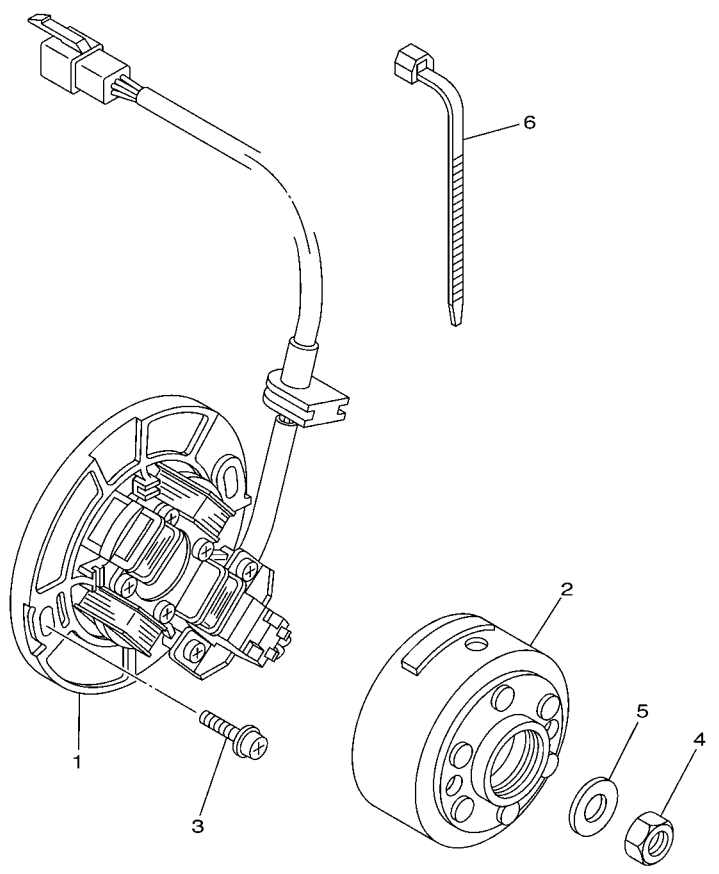


4ES1100-3310

FIG. 31 REAR MASTER CYLINDER

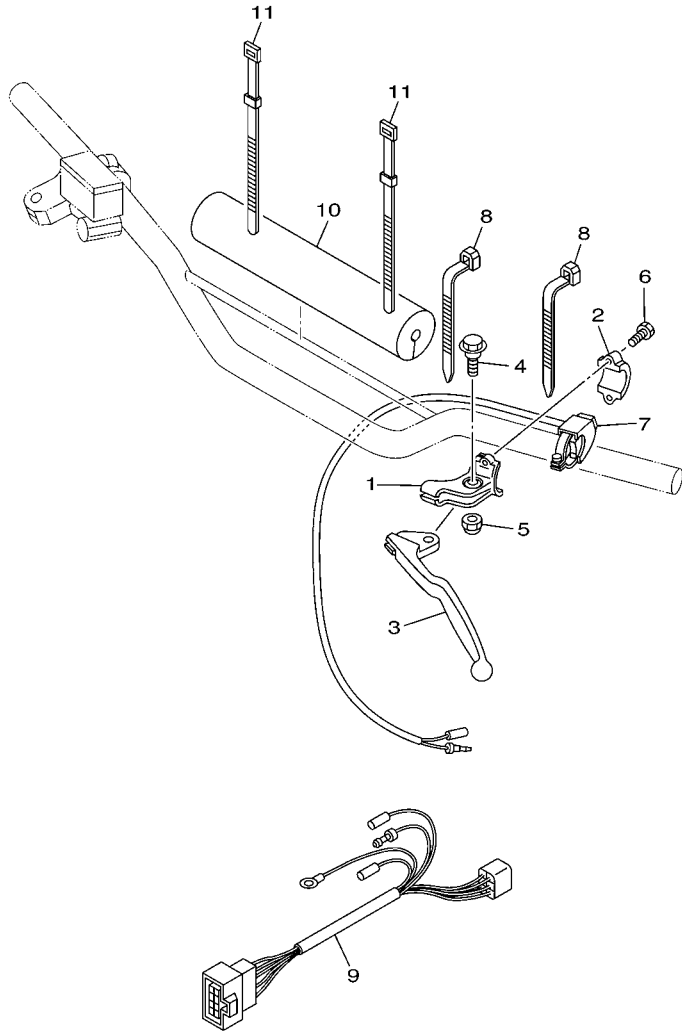
REF. NO.	PART NO.	DESCRIPTION	SPAK	SPAM	SSHK	SSHM	REMARKS
1	4ES-2583V-00	RR. MASTER CYLINDER ASSY.	1	1	1	1	
2	1FK-W0042-50	.CYLINDER KIT, MASTER	1	1	1	1	
3	93210-15620	.O-RING	1	1	1	1	
4	2VN-25866-00	.CIRCLIP	1	1	1	1	
5	2VN-2582A-50	.JOINT	1	1	1	1	
6	2YK-27222-00	.JOINT	1	1	1	1	
7	95307-08600	.NUT	2	2	2	2	
8	4ES-25895-00	HOSE, RESERVOIR	1	1	1	1	
9	90467-11044	CLIP	2	2	2	2	
10	4EW-25894-00	TANK, RESERVOIR	1	1	1	1	
11	3XP-25852-50	CAP, RESERVOIR	1	1	1	1	
12	2VN-25854-00	DIAPHRAGM, RESERVOIR	1	1	1	1	
13	2VN-25855-00	BUSH, DIAPHRAGM	1	1	1	1	
14	90240-08124	PIN, CLEVIS	1	1	1	1	
15	90201-08083	WASHER, PLATE	1	1	1	1	
16	91401-16012	PIN, COTTER	1	1	1	1	
17	95027-06016	BOLT, FLANGE	2	2	2	2	
18	95027-06012	BOLT, FLANGE	1	1	1	1	
19	5PA-25873-01	HOSE, BRAKE 2	1	1			
	5SH-25873-01	HOSE, BRAKE 2			1	1	
20	90401-10168	BOLT, UNION	2	2	2	2	
21	90201-10118	WASHER, PLATE	4	4	4	4	
22	2VM-25876-00	HOLDER, BRAKE HOSE 2	2	2	2	2	
23	98507-05010	SCREW, PAN HEAD	4	4	4	4	

FIG. 32 GENERATOR



REF. NO.	PART NO.	DESCRIPTION	5PAK	5PAM	5SHK	5SHM	REMARKS
1	5PA-85560-01	BASE ASSY	1	1	1	1	
2	4SS-85550-11	ROTOR ASSY	1	1	1	1	
3	90149-06011	SCREW	2	2	2	2	
4	95317-10600	NUT	1	1	1	1	
5	90201-10591	WASHER, PLATE	1	1	1	1	
6	90464-13077	CLAMP	2	2	2	2	
-----							
-----							
-----							
-----							
-----							
-----							
-----							
-----							
-----							
-----							

5PA1100-A320

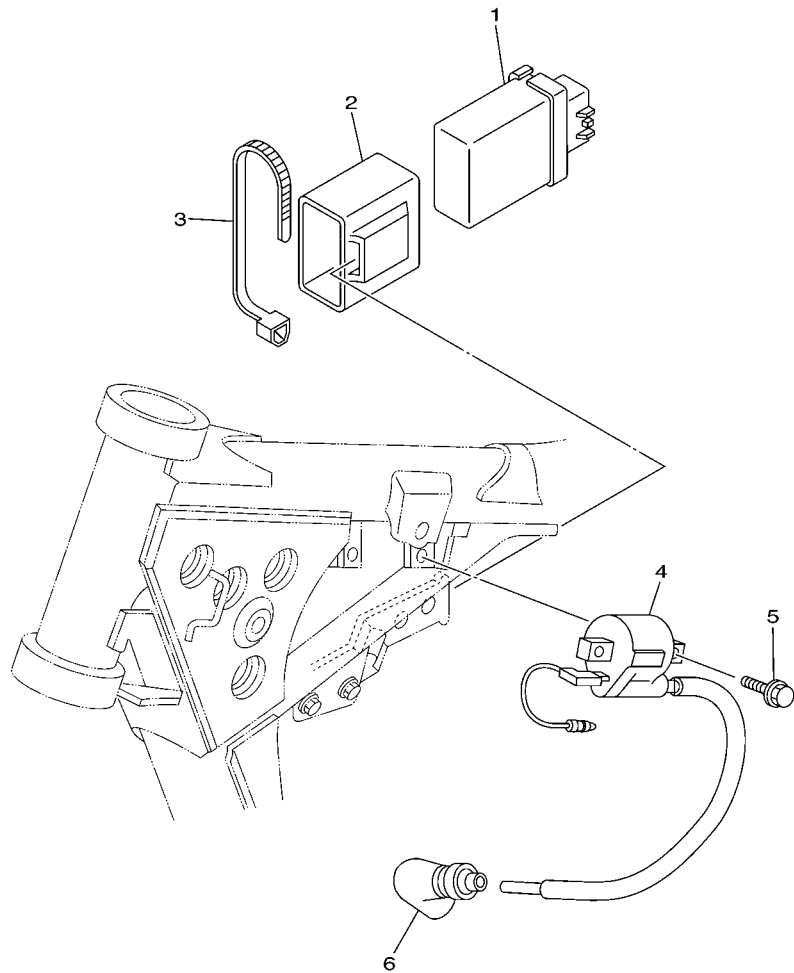


5PAA100-D330

FIG. 33 HANDLE SWITCH & LEVER

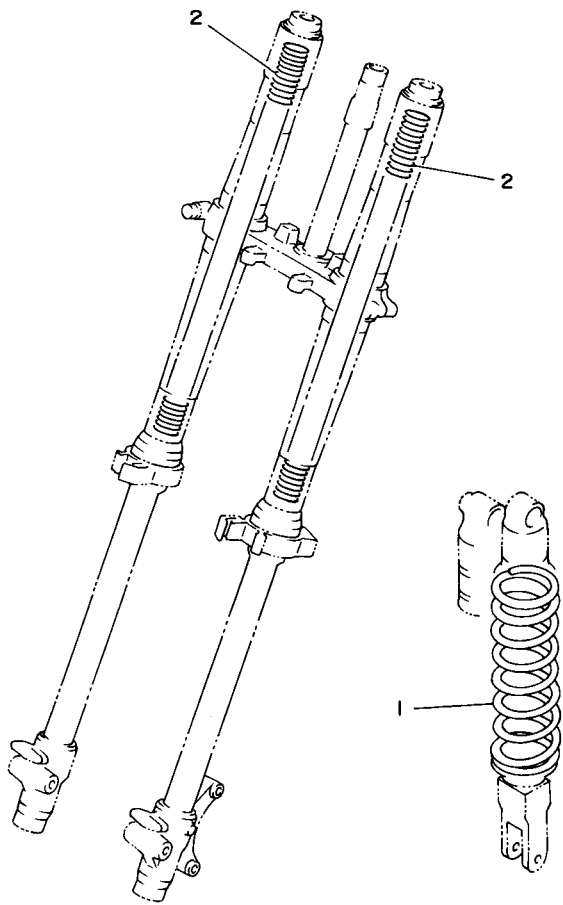
REF. NO.	PART NO.	DESCRIPTION	5PAK	5PAM	5SHK	5SHM	REMARKS
1	38V-82911-00	HOLDER, LEVER 1	1	1	1	1	
2	38V-82913-00	HOLDER, LEVER LOWER 1	1	1	1	1	
3	4GY-83912-00	LEVER 1	1	1	1	1	
4	90109-06799	BOLT	1	1	1	1	
5	95607-06100	NUT, U	1	1	1	1	
6	97007-05016	BOLT	2	2	2	2	
7	22W-83976-01	SWITCH, HANDLE 1	1	1	1	1	
8	90464-13077	CLAMP	2	2	2	2	
9	5PA-82509-00	WIRE, SUB LEAD	1	1	1	1	
10	2X1-26124-00	PROTECTOR, HANDLEBAR	1	1	1	1	
11	437-83936-11	BAND, SWITCH CORD	2	2	2	2	

FIG. 34 ELECTRICAL 1



REF. NO.	PART NO.	DESCRIPTION	SPAK	SPAM	SSHK	SSHM	REMARKS
1	5PA-85540-00	C.D.I. UNIT ASSY	1	1	1	1	
2	5PA-85546-00	BAND	1	1	1	1	
3	90460-15126	CLAMP, HOSE	1	1	1	1	
4	5PA-82310-00	IGNITION COIL ASSY	1	1	1	1	
5	95027-06016	BOLT, FLANGE	2	2	2	2	
6	8DG-82370-00	PLUG CAP ASSY	1	1	1	1	

 5PA1100-A340

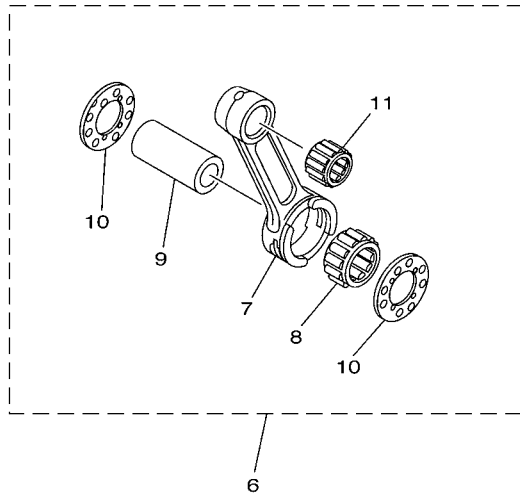
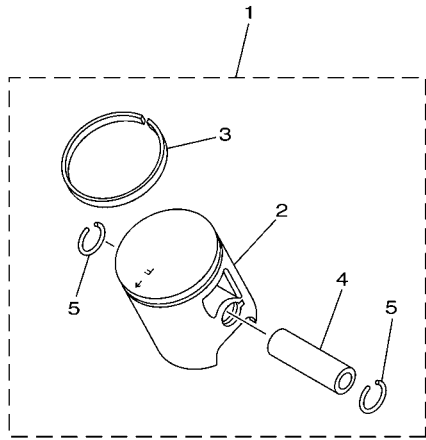


4ES1100-3350

**FIG. 35 ALTERNATE FOR CHASSIS**

REF. NO.	PART NO.	DESCRIPTION	5PAK	5PAM	5SHK	5SHM	REMARKS
1	4ES-22212-M0	SPRING (K=43N/MM)	1				AP FOR EUR
	4ES-22212-K0	SPRING (K=45N/MM)			1		AP FOR EUR
	4ES-22212-G0	SPRING (K=47N/MM)	1	1			AP
	4ES-22212-F0	SPRING (K=49N/MM)			1	1	AP
	4ES-22212-H0	SPRING (K=51N/MM)	1	1			AP EXCEPT FOR EUR
	4ES-22212-J0	SPRING (K=53N/MM)			1	1	AP FOR ZAF
2	4ES-23141-50	SPRING, FRONT FORK(K=2.7N/MM)	2	2			AP
	4ES-23141-40	SPRING, FRONT FORK(K=2.8N/MM)			2	2	AP
	4ES-23141-60	SPRING, FRONT FORK(K=2.9N/MM)	2	2			AP
	4ES-23141-70	SPRING, FRONT FORK(K=3.0N/MM)			2	2	AP





5PA1100-A360

FIG. 36 OPTIONAL PARTS 1

REF. NO.	PART NO.	DESCRIPTION	5PAK	5PAM	5SHK	5SHM	REMARKS
1	5PA-11630-00	PISTON ASSY (STD)	1	1	1	1	
2	5PA-11631-00-B0	.PISTON (STD)	1	1	1	1	ORANGE
3	5PA-11611-00	.RING, PISTON	1	1	1	1	
4	4ES-11633-00	.PIN, PISTON	1	1	1	1	
5	93450-16115	.CIRCLIP	2	2	2	2	
6	4ES-11650-10	CONNECTING ROD ASSY	1	1	1	1	
7	4ES-11651-10	.ROD, CONNECTING	1	1	1	1	
8	93310-420B1	.BEARING	1	1	1	1	
9	2RA-11681-00	.PIN, CRANK 1	1	1	1	1	
10	90209-20159	.WASHER	2	2	2	2	
11	93310-21417	.BEARING	1	1	1	1	

NUMERICAL INDEX

PART NO.	GRID NO.	PART NO.	GRID NO.	PART NO.	GRID NO.	PART NO.	GRID NO.	PART NO.	GRID NO.	PART NO.	GRID NO.
5PA-11111-00	B - 2	5PA-14392-00	B - 7	5PA-15451-00	B - 11	5PA-2118K-20	C - 5	5PA-22210-80	C - 9	5PA-2316A-00	C - 12
5PA-11311-10	B - 2	5PA-14411-00	B - 6	4ES-15461-00	B - 11	5PA-21190-00-33	C - 4	5PA-22210-90	C - 9	5SH-2316A-00	C - 12
4ES-11351-00	B - 2	5PA-14417-00	B - 6	5PA-15463-00	B - 11	5PA-21274-00	C - 4	4ES-22212-F0	C - 9	5PA-23170-00	C - 12
5PA-11400-00	B - 3	5PA-14451-00	B - 6	5PA-15620-01	B - 12	4ES-21511-20	C - 5		D - 15	5PA-23171-00	C - 12
5PA-11412-00	B - 3	5PA-14453-00	B - 6	5PA-15621-00	B - 12	4LB-2151H-02	C - 5	4ES-22212-G0	C - 9	58T-23184-L0	C - 9
5PA-11422-00	B - 3	5PA-14458-00	B - 6	5PA-15641-00	B - 12	3XJ-2151H-A1	C - 5		D - 15	4V4-23188-L0	C - 12
5PA-11611-00	B - 3	5PA-14459-00	B - 6	5PA-15651-00	B - 12	3XJ-2151H-B1	C - 5	4ES-22212-H0	C - 9	4V4-23194-L0	C - 13
	E - 2	4ES-14462-00	B - 6	5PA-15660-00	B - 12	4XL-2153A-10	C - 14		D - 15	4ES-23318-00	C - 14
5PA-11630-00	E - 2	676-14548-00	B - 7	4ES-15664-00	B - 12	4ES-2153E-01	C - 5	4ES-22212-J0	D - 15	5PA-2331E-00	C - 13
5PA-11631-00-A0	B - 3	4MX-14561-00	B - 7	5PA-16111-00	B - 13	5PA-21568-00	C - 5	4ES-22212-K0	C - 9	5PA-23340-01	C - 13
5PA-11631-00-B0	B - 3	5PA-14610-00	B - 9	5PA-16150-10	B - 13	5PA-21611-00	C - 5		D - 15	5NY-23346-L0	C - 13
	E - 2	17W-14615-00	B - 9	5PA-16181-00	B - 13	4ES-21642-00	C - 5	4ES-22212-M0	D - 15	3XJ-23357-L0	C - 12
5PA-11631-00-C0	B - 3	5PA-14642-00	B - 9	21V-16321-00	B - 13	3RV-21668-A0	C - 8	3JD-22214-00	C - 10	4DA-23389-00	C - 11
5PA-11631-00-D0	B - 3	4ES-1469A-00	B - 9	4ES-16321-00	B - 13	3RV-21668-B0	C - 8	4ES-22214-00	C - 9	3JD-23394-00	C - 12
4ES-11633-00	B - 3	5PA-1469A-00	B - 9	131-16324-00	B - 13	5PA-21711-00	C - 6	4ES-22216-00	C - 9	1J7-23415-00	C - 11
	E - 2	5PA-14753-00	B - 9	2TK-16351-00	B - 13	5PA-21721-00	C - 6	4ES-22251-00	C - 10	4ES-23435-00	C - 11
4ES-11650-10	E - 2	4ES-14753-20	B - 9	4ES-16356-00	B - 13	5PH-2172A-10	C - 6	5PA-22253-00	C - 8	3SP-23441-00	C - 11
4ES-11651-10	B - 3	565-14771-00	B - 9	5PA-16357-00	B - 13	5PA-21731-00	C - 6	4AA-22259-40	C - 9	4ES-23485-00	C - 11
	E - 2	5PA-14916-KE	B - 7	5PA-16371-10	B - 13	5PA-2173E-20	C - 6	4AA-22259-50	C - 9	5PA-24110-30	C - 15
2RA-11681-00	B - 3	5PA-14916-KF	B - 7	4ES-16381-00	B - 13	5PA-2173F-20	C - 6	4AA-22259-60	C - 9	4EW-2412F-00	C - 15
	E - 2	5PA-14916-KG	B - 7	4ES-17121-01	B - 14	1FK-21746-00	C - 6	4AA-22259-80	C - 9	3HA-24141-00	C - 4
4BA-12422-00	B - 4	5PA-14916-LE	B - 7	4ES-17131-03	B - 14	5PA-22110-00	C - 7	5PA-22475-00	C - 8	5XE-24144-00	C - 15
4BA-12428-00	B - 4	5PA-14916-LF	B - 7	4ES-17151-10	B - 14	5SH-22110-10	C - 7	5PA-23102-10	C - 12	3ME-2415E-01	C - 5
5PA-12451-00	B - 4	5PA-14916-LG	B - 7	4ES-17161-10	B - 14	5PA-22128-00	C - 7	5SH-23102-10	C - 12	3XJ-2415E-A1	C - 5
5PA-12459-00	B - 4	4MX-14919-00	B - 7	4ES-17211-01	B - 14	4ES-22129-00	C - 7	5PA-23103-10	C - 12	3XJ-2415E-B1	C - 5
5PA-12461-00	B - 5	5HC-14922-00	B - 8	5PA-17221-00	B - 14	5PA-22151-00	C - 7	5SH-23103-10	C - 12	3XJ-2415E-C1	C - 5
22W-12462-00	B - 5	5HC-14934-00	B - 8	4ES-17231-10	B - 14	5PA-22176-00	C - 8	5PA-23110-00	C - 12	4SR-2416E-00	C - 5
22W-12463-00	B - 5	4MX-14943-34	B - 8	5PA-17241-00	B - 14	30X-22178-00	C - 4	4ES-23111-10	C - 12	5PA-24181-00	C - 15
4ES-12481-10	B - 5	4MX-14943-35	B - 8	4ES-17251-00	B - 14	4ES-22178-00	C - 4	5PA-23120-00	C - 12	5PA-24182-00	C - 15
5PA-12482-00	B - 5	4MX-14943-36	B - 8	5PA-17261-00	B - 14	5PA-2217A-00	C - 7	5PA-23125-00	C - 12	5PA-24230-00	C - 6
353-13115-01	B - 10	4MX-14943-84	B - 8	5PA-17411-00	B - 14	4ES-2217F-00	C - 8	3JD-2312G-L0	C - 12	5PA-24240-60	C - 15
5PA-13565-00	B - 6	4MX-14943-85	B - 8	5PA-17421-00	B - 14	4V4-22184-00	C - 4	5PA-23136-10	C - 12	5PA-24311-00	C - 15
4ES-13610-00	B - 6	4MX-14943-86	B - 8	164-17427-00-06	B - 14	5PA-22184-00	C - 8	4LB-23141-10	C - 12	3XJ-24380-00	C - 15
4ES-13613-00	B - 6	4MX-14943-87	B - 8	164-17427-00-08	B - 14	5PA-22199-00	C - 7	4ES-23141-40	C - 12	4DP-24500-01	C - 15
4ES-13616-00	B - 6	5PA-14947-00	B - 8	164-17427-00-10	B - 14	5SH-22201-30	C - 9		D - 15	4X8-24512-00	C - 15
5PA-14101-00	B - 7	4MX-14948-04	B - 7	5PA-18101-00	C - 3	5SH-22201-40	C - 9	4ES-23141-50	D - 15	3AC-24523-00	C - 15
5PA-14105-00	B - 7	4MX-14948-05	B - 7	2HF-18110-02	C - 3	5PA-22201-50	C - 9	4ES-23141-60	D - 15	3AJ-24534-01	C - 15
5PA-1410E-00	B - 7	4MX-14948-06	B - 7	5PA-1811E-00	C - 3	5SH-22201-50	C - 9	4ES-23141-70	D - 15	5NY-24610-00	C - 15
4MX-14115-00	B - 7	5PA-1496A-00	B - 8	5PA-18140-00	C - 3	5PA-22201-60	C - 9	4ES-23142-00	C - 12	5PA-2470F-10	D - 2
5PA-14126-00	B - 7	5PA-14984-00	B - 7	4ES-18511-02	C - 2	5PA-22201-70	C - 9	4ES-23144-00	C - 12	5PA-24718-00	D - 2
5PA-14131-00	B - 7	5PA-14985-00	B - 7	5R2-18512-00	C - 2	5PA-22201-80	C - 9	4ES-23145-00	C - 12	5PA-24728-00	D - 2
3TJ-14137-40	B - 8	5PA-15111-00	B - 10	4ES-18513-01	C - 2	5PA-22201-90	C - 9	5K5-23149-00	C - 12	5PA-24770-20	D - 2
5PA-14146-00	B - 8	5PA-15118-00	B - 10	4BA-18531-00	C - 2	5SH-22210-30	C - 9	5PA-23149-00	C - 12	4LB-25104-00	D - 3
5PA-14159-00	B - 7	5PA-15121-10	B - 10	4BA-18535-00	C - 2	5SH-22210-40	C - 9	4ES-2314F-00	C - 13	4ES-25104-20	D - 3
4JT-14171-00	B - 7	3Y1-15363-00	B - 11	4ES-18540-00	C - 2	5PA-22210-50	C - 9	5PA-2314H-L0	C - 13	4ES-25111-00	D - 3
5PA-14194-00	B - 8	4ES-15411-00	B - 11	5PA-21101-11-33	C - 4	5SH-22210-50	C - 9	5PA-2314J-L0	C - 13	4ES-25181-00	D - 3
4XL-14197-10	B - 7	5PA-15415-10	B - 11	5PA-2118K-00	C - 5	5PA-22210-60	C - 9	4A1-23156-00	C - 12	22W-25181-01	C - 7
5PA-14340-00	B - 7	5PA-15431-00	B - 11	5PA-2118K-10	C - 5	5PA-22210-70	C - 9	2HH-23158-L0	C - 12	4ES-25183-10	D - 3

NUMERICAL INDEX

PART NO.	GRID NO.	PART NO.	GRID NO.	PART NO.	GRID NO.	PART NO.	GRID NO.	PART NO.	GRID NO.	PART NO.	GRID NO.
1T1-25194-00	D - 3	4ES-25920-00	D - 7	4EW-W0057-50	D - 7	90179-22412	C - 11	90240-08124	D - 11	90467-11044	D - 11
4LB-25304-00	D - 5	56A-25926-00	D - 4	5XE-W2587-00	D - 9	90179-25033	C - 11	90240-10004	D - 10	90468-23194	B - 12
4ES-25304-20	D - 5	3GD-25933-00	D - 7	90101-08475	D - 6	90183-06023	C - 5	90250-06013	C - 2	90480-15528	B - 5
4ES-25311-00	D - 5	56A-25937-00	D - 4	90101-12755	C - 8	90185-08169	D - 6	90267-48138	B - 6	90480-16561	B - 9
4ES-25381-01	D - 6	5R2-25937-00	D - 4	90105-06078	D - 7	90185-10110	C - 10	90280-03017	B - 3	90480-18411	B - 9
4ES-25383-00	D - 5	1UY-25937-51	D - 7	90105-08126	B - 10	90185-12046	D - 3	90282-05001	B - 13	90480-18549	C - 15
4ES-25383-10	D - 6	5PA-26111-00	D - 8	90105-08211	D - 4	90185-12119	C - 8	90336-06031	B - 12	90501-12081	B - 12
5PA-25388-00	D - 6	2X1-26124-00	D - 13	90105-10110	C - 4	90185-14142	D - 6	90338-10150	C - 8	90501-204A0	B - 13
1T2-25394-00	D - 5	4GY-26241-00	D - 8	90105-10111	C - 4	90201-043H7	B - 6	90380-10218	C - 7	90506-15480	D - 10
5X2-25394-00	D - 5	4GY-26242-00	D - 8	90105-10582	C - 7	90201-06060	B - 12	90380-12219	C - 8	90507-20052	B - 9
5PA-25446-00	D - 5	22W-26243-00	D - 8	90105-10614	C - 10			90381-12091	C - 8	90508-14016	B - 13
4ES-25447-20	D - 5	5X2-26281-00	D - 8	90105-12382	C - 8	90201-06086	B - 9	90385-17042	C - 7	90508-24007	C - 3
5PA-25448-00	D - 5	322-26282-00	D - 8	90109-065F3	B - 6	90201-06089	B - 9	90387-06027	C - 15	90508-26750	B - 12
5PA-25449-00	D - 5	5X2-2628H-01	D - 8	90109-06799	D - 13	90201-08083	D - 11	90387-0614M	B - 5	90508-282B8	D - 10
5PA-25451-00	D - 5	5PA-26311-00	D - 8	90109-081G2	D - 6	90201-080L8	B - 2	90387-062X0	C - 7	90508-282B9	D - 10
5PA-25452-00	D - 5	4ES-26335-11	D - 8	90109-08718	D - 7	90201-081R9	C - 4	90387-063G3	B - 9	90508-32016	C - 3
5PA-25453-00	D - 6	498-26372-00	D - 8	90109-10729	C - 10	90201-08512	B - 4	90387-064X4	C - 5	91401-16012	D - 11
5CG-25715-00	D - 9	5NY-26372-00	D - 9	90110-08096	C - 4	90201-086P8	D - 6	90387-067K6	C - 4	91401-20025	D - 10
5PA-2580T-00	D - 4	4ES-27114-00	D - 7		D - 7	90201-10118	D - 9	90387-0701A	C - 5	91401-25015	D - 10
5PA-2580W-00	D - 7	5PA-27211-00	D - 10	90116-08027	B - 2			90387-105L0	B - 9	92012-06010	B - 9
3GD-25827-00	D - 7	2YK-27222-00	D - 11	90116-08028	B - 2	90201-10119	D - 10	90387-1200U	C - 7	92017-06040	C - 7
2VN-2582A-50	D - 11	5PA-27311-00	D - 10	90116-08031	B - 2	90201-10591	D - 12	90387-124H0	D - 3	92903-04600	B - 7
5PA-2582T-00	D - 4	5SH-27311-00	D - 10	90119-05001	B - 13	90201-112U6	C - 10	90387-127J7	C - 7	92907-03100	B - 6
5PA-2582W-00	D - 7	5ET-27411-00	D - 10	90119-06001	C - 6	90201-12362	D - 3	90387-127J8	C - 7	92907-10600	C - 10
5MV-25833-00	D - 9	5ET-27421-00	D - 10	90119-06063	C - 5	90201-124F8	B - 12	90387-202A0	B - 15	93101-12173	C - 3
4ES-2583V-00	D - 11	4ES-27491-00	D - 7	90119-06118	C - 4	90201-124G9	C - 7	90387-20488	B - 13	93101-17062	C - 8
5MV-25852-01	D - 9	5PA-82310-00	D - 14	90119-06181	B - 5	90201-12749	C - 8	90387-227H7	D - 8	93102-12106	B - 4
3XP-25852-50	D - 11	8DG-82370-00	D - 14	90119-06185	C - 5	90201-127J6	C - 8	90401-10168	D - 9	93102-12224	B - 13
5XE-25853-00	D - 9	5PA-82509-00	D - 13	90119-06190	C - 15	90201-152L7	D - 6		D - 11	93102-17263	B - 12
2VN-25854-00	D - 11	38V-82911-00	D - 13	90119-06192	C - 5	90201-15700	D - 10	90430-06166	B - 4	93102-20009	D - 5
5XE-25854-00	D - 9	38V-82913-00	D - 13	90119-06217	B - 9	90201-171G6	B - 13	90430-08119	B - 11	93102-20447	B - 3
2VN-25855-00	D - 11	4GY-83912-00	D - 13	90119-06225	C - 6	90201-17545	B - 14	90445-08376	B - 10	93102-26042	B - 15
2VN-25866-00	D - 11	5MV-83922-00	D - 9	90122-06002	B - 6	90201-17558	B - 13	90445-09220	C - 15	93102-28009	B - 3
5MV-25867-00	D - 9	437-83936-11	D - 13	90123-08046	D - 8	90201-176L4	B - 12	90445-09300	C - 15	93106-20031	D - 3
5NY-25868-00	D - 9	22W-83976-01	D - 13	90149-06011	C - 15	90201-177G4	C - 3	90450-25037	B - 5	93109-11073	B - 4
5SH-25872-01	D - 9	5PA-85540-00	D - 14		D - 12	90201-20611	B - 14	90450-28014	B - 5	93109-17071	C - 7
4ES-25872-11	D - 9	5PA-85546-00	D - 14	90149-06327	D - 4	90201-220T0	C - 11	90450-99064	B - 6	93210-11073	D - 10
5PA-25873-01	D - 11	4SS-85550-11	D - 12		D - 7	90201-256K5	C - 11	90460-15126	D - 14	93210-12152	B - 12
5SH-25873-01	D - 11	5PA-85560-01	D - 12	90151-06045	B - 12	90201-33299	B - 9	90460-41191	B - 6	93210-15620	D - 11
2VM-25876-00	D - 11	5NY-W0041-00	D - 9	90157-05079	C - 11	90202-05193	C - 15	90460-56105	B - 6	93210-19123	B - 11
4EW-25894-00	D - 11	1FK-W0042-50	D - 11	90157-06071	B - 14	90208-12015	B - 13	90461-10136	B - 10	93210-56459	B - 2
4ES-25895-00	D - 11	5PA-W0045-00	D - 4	90159-06078	C - 6	90209-06096	B - 6	90464-13077	B - 5	93210-84724	B - 2
5MV-2589F-00	D - 9	5PA-W0046-50	D - 7	90159-06182	C - 6	90209-06187	C - 5		D - 12	93306-00105	B - 4
34X-25914-00	D - 4	4ES-W0047-00	D - 7	90176-08005	B - 2	90209-14008	B - 14		D - 13	93306-00203	D - 5
1UY-25917-51	D - 7	4ES-W0047-10	D - 4	90179-08019	B - 2	90209-16209	B - 14	90465-13275	C - 15	93306-20120	D - 3
56A-25919-00	D - 4	51L-W0048-00	D - 4	90179-08148	D - 8	90209-20159	B - 3	90467-08002	B - 5	93306-20203	D - 5
56A-25919-10	D - 4	1UY-W0048-50	D - 7	90179-12659	B - 13		E - 2	90467-09002	C - 15	93306-20333	B - 14
1UY-25919-51	D - 7	4ES-W0057-10	D - 4	90179-16226	B - 15	90215-20261	B - 15	90467-10008	C - 15	93306-20401	B - 15

NUMERICAL INDEX

PART NO.	GRID NO.	PART NO.	GRID NO.	PART NO.	GRID NO.	PART NO.	GRID NO.	PART NO.	GRID NO.	PART NO.	GRID NO.
93306-20438	B - 3	95022-06025	B - 4	98706-04012	D - 9						
93306-30421	B - 3		B - 9	98707-04012	D - 8						
93310-21417	B - 3		B - 11	98707-06025	C - 15						
	E - 2	95022-06030	B - 11	99009-10400	C - 2						
93310-420B1	B - 3	95022-06035	B - 11	99009-12400	B - 12						
	E - 2	95022-06040	B - 11	99009-17400	C - 3						
93315-11206	B - 13	95022-08080	B - 11	99009-35500	D - 5						
93315-21455	C - 7	95024-06010	C - 13	99530-08016	B - 11						
93315-31502	B - 14	95027-06012	C - 4	99530-10014	B - 10						
93317-11245	B - 14		C - 11		B - 11						
93317-21746	C - 7		D - 2	99590-10114	B - 2						
93317-31771	C - 7		D - 11	9Y582-00117	D - 6						
93332-00079	C - 11	95027-06014	C - 7	9Y582-00123	D - 6						
93410-20038	B - 14	95027-06016	C - 15								
93440-07182	B - 4		D - 11								
93440-15012	B - 14		D - 14								
93440-17064	B - 14	95027-06020	C - 14								
93450-16115	B - 3	95027-08012	C - 4								
	E - 2	95027-08030	C - 11								
93503-16003	B - 13	95027-08050	C - 7								
93507-32009	B - 12	95307-08600	D - 11								
9382A-14227	B - 15	95307-08700	D - 6								
9382A-15228	B - 15	95317-10600	D - 12								
94107-17012	D - 3	95607-06100	D - 13								
94107-17019	D - 3	95607-06200	C - 7								
94107-19012	D - 3	95607-08200	C - 7								
94107-19015	D - 3	95607-10200	C - 4								
94109-14012	D - 5		C - 7								
94109-14015	D - 5	95607-12200	C - 8								
94109-16012	D - 5	95617-12100	C - 7								
94109-16015	D - 5	95701-06500	D - 9								
94207-17284	D - 3	95807-08035	C - 11								
94207-19290	D - 3	95817-08125	C - 4								
94208-14285	D - 5	95822-06010	B - 5								
94209-16291	D - 5	95822-06060	B - 4								
94307-16171	D - 5	97007-05016	D - 13								
94307-17166	D - 3	97022-06020	C - 3								
94307-19170	D - 3	98502-06030	B - 11								
94308-14165	D - 5	98502-06040	B - 10								
94414-17530	D - 3	98502-06050	B - 10								
94414-19521	D - 3	98502-06060	B - 10								
94416-14529	D - 5	98502-06070	B - 10								
94418-16522	D - 5	98504-04012	B - 8								
94682-00001	D - 6	98504-04014	B - 7								
94702-00368	B - 2	98507-03008	B - 6								
94709-00368	B - 2		C - 15								
95022-06012	B - 12	98507-05010	D - 11								
95022-06020	B - 6	98507-05016	D - 8								